

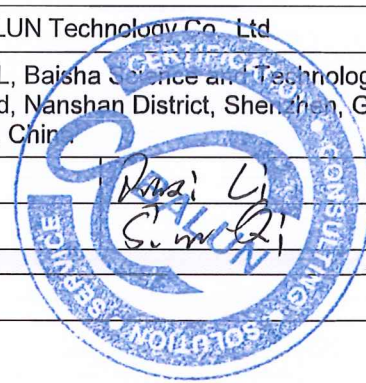

<b>TEST REPORT</b> <b>IEC 62109-1</b> <b>Safety of Power Converter for use in Photovoltaic Power Systems</b> <b>Part 1: General requirements</b>	
Report Number..... :	BL-SZ19B0347-B01
Date of issue..... :	Nov. 89, 2019
Total number of pages .....	66
Name of Testing Laboratory preparing the Report .....	Shenzhen BALUN Technology Co., Ltd
Applicant's name .....	EVOLVE ENERGY GROUP CO., LIMITED
Address..... :	RM 702, 7/F FU FAI COMM CTR 27 HILLIER ST SHEUNG WAN, HK
<b>Test specification:</b>	
Standard .....	IEC 62109-1:2010 (First Edition)
Test procedure .....	Test report
Non-standard test method .....	N/A
Test Report Form No. .... :	IEC62109_1B
Test Report Form(s) Originator .... :	VDE Testing and Certification Institute
Master TRF .....	Dated 2016-04
<b>Copyright © 2016 IEC System of Conformity Assessment Schemes for Electrotechnical Equipment and Components (IECEE System). All rights reserved.</b> This publication may be reproduced in whole or in part for non-commercial purposes as long as the IECEE is acknowledged as copyright owner and source of the material. IECEE takes no responsibility for and will not assume liability for damages resulting from the reader's interpretation of the reproduced material due to its placement and context. If this Test Report Form is used by non-IECEE members, the IECEE/IEC logo and the reference to the CB Scheme procedure shall be removed. <b>This report is not valid as a CB Test Report unless signed by an approved CB Testing Laboratory and appended to a CB Test Certificate issued by an NCB in accordance with IECEE 02.</b>	

Test item description..... :	PV Grid inverter	
Trade Mark..... :	<b>EVVO</b>	
Manufacturer..... :	Same as the applicant	
Model/Type reference..... :	EVVO 1100TL-AV, EVVO 1600TL-AV, EVVO 2200TL-AV, EVVO 2700TL-AV, EVVO 3000TL-AV, EVVO 3200TL-AV	
Ratings..... :	See copy of marking label and model list.	
<b>Responsible Testing Laboratory (as applicable), testing procedure and testing location(s):</b>		
<input checked="" type="checkbox"/> Testing Laboratory:	Shenzhen BALUN Technology Co., Ltd	
Testing location/ address..... :	Block B, 1st FL, Baisha Science and Technology Park, Shahe Xi Road, Nanshan District, Shenzhen, Guangdong Province, P.R. China	
Tested by (name, function, signature)..... :	Ruoxi Li	
Approved by (name, function, signature).... :	Simon Qi	
<input type="checkbox"/> Testing procedure: CTF Stage 1:		
Testing location/ address..... :		
Tested by (name, function, signature)..... :		
Approved by (name, function, signature).... :		
<input type="checkbox"/> Testing procedure: CTF Stage 2:		
Testing location/ address..... :		
Tested by (name + signature)..... :		
Witnessed by (name, function, signature) .:		
Approved by (name, function, signature).... :		
<input type="checkbox"/> Testing procedure: CTF Stage 3:		
<input type="checkbox"/> Testing procedure: CTF Stage 4:		
Testing location/ address..... :		
Tested by (name, function, signature)..... :		
Witnessed by (name, function, signature) .:		
Approved by (name, function, signature).... :		
Supervised by (name, function, signature) :		



**List of Attachments (including a total number of pages in each attachment):**

ATTACHMENT 1 – Test report of IEC 62109-2: 2011 (1st Edition) (25 pages)

ATTACHMENT 2 – Photo documentation (6 pages)

**Summary of testing:****Tests performed (name of test and test clause):**

4.2.2.6 Mains supply electrical data in normal condition  
4.3 Thermal testing  
4.4 Testing in fault condition  
4.5 Humidity preconditioning  
4.7 Electrical ratings tests  
5.1.2 Durability of markings  
6.3 Ingress protection  
7.3.4.2.3 Access probe tests  
7.3.5.3.2 Limitation of discharging energy through protective impedance  
7.3.6.3 Protective class I - Protective bonding and earthing  
7.3.7.4,7.3.7.5 Clearance and Creepage distances  
7.3.9 Protection against shock hazard due to stored energy  
7.4 Protection against energy hazards  
7.5.1 Impulse voltage test  
7.5.2 Voltage test (dielectric strength test)  
7.5.4 Touch current measurement  
8.2 Moving parts  
8.3 Stability  
8.4 Provisions for lifting and carrying  
8.5 Wall mounting  
9.1.3 Materials requirements for protection against fire hazard  
10.2 Sonic pressure and sound level  
13.1 Handles and manual controls  
13.7 Mechanical resistance to deflection, impact or drop

**Remark:**

- The max.operating temperature is 60°C specified by manufacturer, the temperature rise tests were conducted at the max.rated ambient temperature of 45°C or 60°C (derating) in the chamber.

- For the temperature rise tests were conducted on PCE power derating curve at most unfavourable operating

**Testing location:**

All tests as described in Test Case and Measurement Sections were performed at the laboratory described on page 2









<p>conditions, see instruction manual for details.</p> <ul style="list-style-type: none"><li>- Other testing conditions considered in this test report, see General Product Information on the following pages.</li></ul>	
---	--

**Summary of compliance with National Differences (List of countries addressed): None.**

**The product fulfils the requirements of IEC 62109-1: 2010, EN 62109-1: 2010, IEC 62109-2: 2011, EN 62109-2: 2011.**

**Copy of marking plate:**

The artwork below may be only a draft. The use of certification marks on a product must be authorized by the respective NCBs that own these marks.

<b>EVVO</b>	Solar Grid-tied Inverter
Model No:	EVVO 3200TL - AV
Max. DC Input Voltage	550V
Operating MPPT Voltage Range	50~550V
Max. Input Current	12A
Max. PV Isc	15A
Nominal Grid Voltage	L/N/PE, 230Vac
Max. Output Current	16A
Nominal Grid Frequency	50/60Hz
Max. Output Power	3300VA
Power Factor	1 (adjustable+/-0.8)
Ingress Protection	IP65
Operating Temperature Range	-30°C~+60°C
Protective Class	Class I
Inverter Topology	Non-Isolated
Factory - Shenzhen China	
Manufacturer : EVOLVE ENERGY GROUP CO., LIMITED	
Address : RM 702, 7/F FU FAI COMM CTR 27 HILLIER ST SHEUNG WAN, HK	
Global Head Quarters	
371 Sidco Industrial Estate	
Chennai 600098 India	
VDE0126-1-1, VDE-AR-N4105, IEC61727, IEC62116, UTE C15-712-1, AS4777	
       	

**Note:**

1. The above markings are the minimum requirements required by the safety standard. For the final production samples, the additional markings which do not give rise to misunderstanding may be added.
2. Label is attached on the side surface of enclosure and visible after installation
3. Labels of other models are as the same with EVVO 3200TL-AV's except the parameters of rating.

<b>Test item particulars</b> .....:			
<b>Equipment mobility</b> .....	<input type="checkbox"/> movable	<input type="checkbox"/> hand-held	<input type="checkbox"/> stationary
	<input checked="" type="checkbox"/> fixed	<input type="checkbox"/> transportable	<input type="checkbox"/> for building-in
<b>Connection to the mains</b> .....	<input type="checkbox"/> pluggable equipment	<input type="checkbox"/> direct plug-in	
	<input checked="" type="checkbox"/> permanent connection	<input type="checkbox"/> for building-in	
<b>Environmental category</b> .....	<input checked="" type="checkbox"/> outdoor	<input type="checkbox"/> indoor unconditional	<input type="checkbox"/> indoor conditional
<b>Over voltage category Mains</b> .....	<input type="checkbox"/> OVC I	<input type="checkbox"/> OVC II	<input checked="" type="checkbox"/> OVC III
	<input type="checkbox"/> OVC IV		
<b>Over voltage category PV</b> .....	<input type="checkbox"/> OVC I	<input checked="" type="checkbox"/> OVC II	<input type="checkbox"/> OVC III
	<input type="checkbox"/> OVC IV		
<b>Mains supply tolerance (%)</b> .....	According to the specified supply range.		
<b>Tested for power systems</b> .....	TN		
<b>IT testing, phase-phase voltage (V)</b> .....:	N/A		
<b>Class of equipment</b> .....:	<input checked="" type="checkbox"/> Class I	<input type="checkbox"/> Class II	<input type="checkbox"/> Class III
	<input type="checkbox"/> Not classified		
<b>Mass of equipment (kg)</b> .....	6.3		
<b>Pollution degree</b> .....:	PD3(Inside PD2)		
<b>IP protection class</b> .....:	IP65		
.....:			
<b>Possible test case verdicts:</b>			
- test case does not apply to the test object.....:	N/A		
- test object does meet the requirement.....:	P (Pass)		
- test object was not evaluated for the requirement .....	N/E		
- test object does not meet the requirement.....:	F (Fail)		
<b>Testing</b> .....:			
<b>Date of receipt of test item</b> .....	Nov. 15, 2019		
<b>Date (s) of performance of tests</b> .....	N/A		

**General remarks:**

"(See Enclosure #)" refers to additional information appended to the report.

"(See appended table)" refers to a table appended to the report.

The tests results presented in this report relate only to the object tested.

This report shall not be reproduced except in full without the written approval of the testing laboratory.

List of test equipment must be kept on file and available for review.

Additional test data and/or information provided in the attachments to this report.

**Throughout this report a  comma /  point is used as the decimal separator.**

Determination of the test results includes consideration of measurement uncertainty from the test equipment and methods.

**Manufacturer's Declaration per sub-clause 4.2.5 of IEC 60384-14:**

The application for obtaining a CB Test Certificate includes more than one factory location and a declaration from the Manufacturer stating that the sample(s) submitted for evaluation is (are) representative of the products from each factory has been provided .....

**Yes**  
 **Not applicable**

**When differences exist; they shall be identified in the General product information section.**

**Name and address of factory (ies) .....** : Same as applicant.

**General product information:**Brief description:

The PCE under test (EUT) is PV Grid inverter. During inverter, which convert the variable DC power generated from the photovoltaic (PV) arrays to the stable utility AC power which can be fed into the commercial electrical grid.

The EUT in this report is same with the testing samples of report No. BL-SZ1930601-B01 which was issued by Shenzhen BALUN Technology Co., Ltd. on Apr. 10, 2019, only with different applicant information, model name, brand name, label and appearance, So all the test data reference from the report BL-SZ1930601-B01, which was issued by Shenzhen BALUN Technology Co., Ltd. on Apr. 10, 2019.

The PCE under test is single-phase PV Grid inverter for solar power generation with the rating of 3.3kW, 2.7kW, 2.2kW, 1.6kW and 1.1kW.

The external circuit breakers or fuses for PV array and Grid connection are required which the statements are provided in the installation manual.

The models of EVVO 1100TL-AV, EVVO 1600TL-AV, EVVO 2200TL-AV, EVVO 2700TL-AV, EVVO 3000TL-AV and EVVO 3200TL-AV are identical on topological schematic circuit diagram and control solution codes. The difference between each other as following table:

Model Item	EVVO 1100TL-AV	EVVO 1600TL-AV	EVVO 2200TL-AV	EVVO 2700TL-AV	EVVO 3000TL-AV	EVVO 3200TL-AV
Heat sink size	253*253.3*26.5mm			271*253.3*40mm		
Inverter inductance	0.99mH * 2pcs			0.676mH * 2 pcs		
Bus capacitance	470uF /500V* 2 pcs			470uF/550V * 3 pcs		
size	303X260.5X118			321X260.5X131.5		
weight	5.5kg			6.3kg		
Operating voltage range	50-500V			50-550V		
Grid-connected starting voltage	70V			70V		
Full load MPPT range	110-450V	150-450V	200-450V	250-500V	275-500V	300-500V
Max. Input power	1500W	2200W	3000W	3700W	4100W	4500W
Max. Output current	5.3A	7.7A	10.6A	13A	14.5A	16A
Max. Output power	1100VA	1600VA	2200VA	2700VA	3000VA	3300VA

Unless otherwise specified, all the tests were conducted on the basic model of EVVO 3200TL-AV.

The PCE does not provide galvanic separation between the PV array and Grid connection circuit (Non-isolation or transformer-less type).

The Grid connection circuit can be switched off by two relays in series for the redundant protection. When single-fault occurs to one relay, the other redundant one will still maintain the basic insulation between PV array, Batteries and Grid connection to the mains. All the relays have functional self-checking before the PCE starting.

Block Diagram:



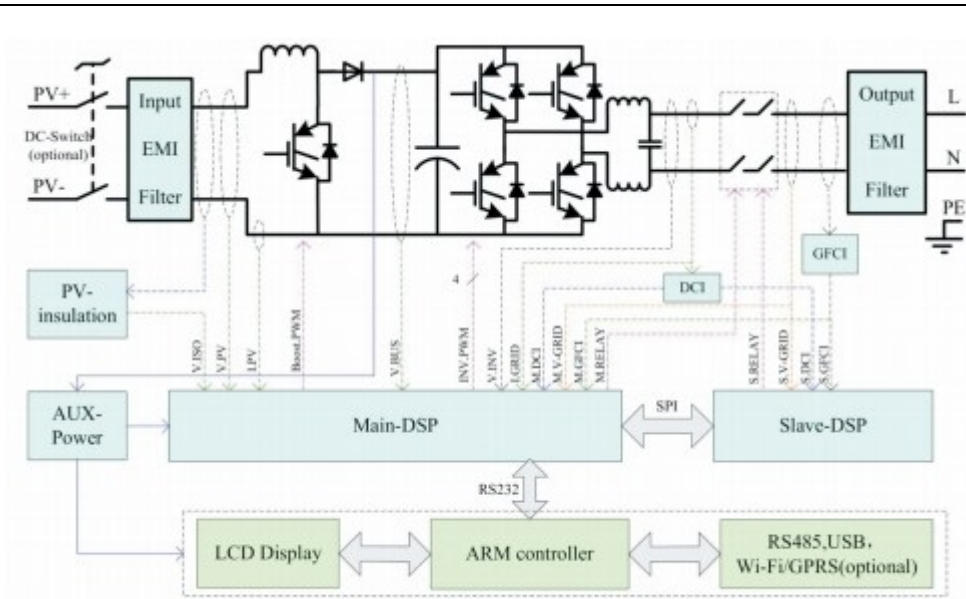

Throughout the test report following abbreviations may be used:

- input	i/p	- Test repeated, similar result(3 times)	TRSR
- output	o/p	- No indication of dielectric breakdown	NB
- short-circuited	s-c	- Cheesecloth remained intact	NC
- overloaded	o-l	- Tissue paper remained intact	NT
- open-circuited	o-c	- No hazards	NH
- normal conditions	N.C.	- The PCE can recover to operate automatically after removing the abnormal condition	RO
- single fault conditions	SFC	- functional insulation	FI
- between parts of opposite polarity	BOP	- basic insulation	BI
- internal protection operated	IPO	- supplementary insulation	SI
- Component damage (list damaged component)	CD	- double insulation	DI
- No component damaged	NCD	- reinforced insulation	RI
- Power Conversion Equipment Indicate used abbreviations (if any)	PCE	- Equipment Under Test	EUT

IEC 62109-1			
Clause	Requirement – Test	Result – Remark	Verdict
<b>4</b>	<b>GENERAL TESTING REQUIREMENTS</b>		P
4.1	General		P
4.2	General conditions for testing		P
4.2.1	Sequence of tests		P
4.2.2	Reference test conditions		P
4.2.2.1	Environmental conditions	Ambient environmental condition compliance.	P
4.2.2.2	State of equipment	Test carried on a complete EUT.	P
4.2.2.3	Position of equipment	The equipment was installed in accordance with the manufacturer's instructions.	P
4.2.2.4	Accessories	Accessories and operator-interchangeable parts available from, or recommended by the manufacturer according to the installation manual required.	P
4.2.2.5	Covers and removable parts	No covers or parts, which can be removed without using a TOOL.	N/A
4.2.2.6	Mains supply a) Voltage: b) Frequency: c) Polarity: d) Earthing: e) Over-current Protection:	(see appended table 4.2.2.6)	P
4.2.2.7	Supply ports other than the mains		P
4.2.2.7.1	Photovoltaic supply sources a) Open circuit voltage: b) Short-circuit current:	(see appended table 4.2.2.7)	P
4.2.2.7.2	Battery inputs	No battery.	N/A
4.2.2.8	Conditions of loading for output ports	The least favorable loading conditions was considered. Until steady condition was established.	P
4.2.2.9	Earthing terminals	Connection to the earth	P
4.2.2.10	Controls	Any position was set.	P
4.2.2.11	Available short circuit current	Considered.	P
4.3	Thermal testing	(see appended table 4.3)	P

<b>IEC 62109-1</b>			
Clause	Requirement – Test	Result – Remark	Verdict
4.3.1	General		P
4.3.2	Maximum temperatures		P
4.3.2.1	General		P
4.3.2.2	Touch temperatures		P
4.3.2.3	Temperature limits for mounting surfaces		P
4.4	Testing in single fault condition	(see appended table 4.4)	P
4.4.1	General		P
4.4.2	Test conditions and duration for testing under fault conditions		P
4.4.2.1	General		P
4.4.2.2	Duration of tests		P
4.4.3	Pass/fail criteria for testing under fault conditions		P
4.4.3.1	Protection against shock hazard		P
4.4.3.2	Protection against the spread of fire		P
4.4.3.3	Protection against other hazards		P
4.4.3.4	Protection against parts expulsion hazards		P
4.4.4	Single fault conditions to be applied	See below.	P
4.4.4.1	Component fault tests	(see appended table 4.4)	P
4.4.4.2	Equipment or parts for short-term or intermittent operation	Continuous operation equipment.	N/A
4.4.4.3	Motors	Not used.	N/A
4.4.4.4	Transformer short circuit tests	(see appended table 4.4)	P
4.4.4.5	Output short circuit	(see appended table 4.4)	P
4.4.4.6	Backfeed current test for equipment with more than one source of supply	Considered	P
4.4.4.7	Output overload	(see appended table 4.4)	P
4.4.4.8	Cooling system failure	(see appended table 4.4)	P
4.4.4.9	Heating devices	No heating devices used.	N/A
4.4.4.10	Safety interlock systems	No safety interlock device used.	N/A
4.4.4.11	Reverse d.c. connections	(see appended table 4.4)	P
4.4.4.12	Voltage selector mismatch	No voltage selector used.	N/A
4.4.4.13	Mis-wiring with incorrect phase sequence or polarity	DC mains supply.	N/A
4.4.4.14	Printed wiring board short-circuit test	(see appended table 4.4)	P
4.5	Humidity preconditioning	(see appended table 7.5)	P

<b>IEC 62109-1</b>			
Clause	Requirement – Test	Result – Remark	Verdict
4.5.1	General		P
4.5.2	Conditions	Humidity: 93%RH Temperature: 40°C Duration: 48hrs	P
4.6	Backfeed voltage protection	Hazardous voltage and energy was not present on the terminals, with the DC mains supply source de-energized or disconnected. In addition the symbol 13 of Table C.1 was marked for servicing functions	P
4.6.1	Backfeed tests under normal conditions	Relay or Contactor is available at AC output side to prevent back-feed current from AC to DC side.	P
4.6.2	Backfeed tests under single-fault conditions	Relay or contactor is available at AC output side and with auto disconnected device at DC input side to prevent backfeed current from AC to DC side, even if under single-fault conditions.	P
4.6.3	Compliance with backfeed tests	See above.	N/A
4.7	Electrical ratings tests	(see appended table 4.2.2.6)	P
4.7.1	Input ratings		P
4.7.1.1	Measurement requirements for DC input ports		P
4.7.2	Output ratings		P
<b>5</b>	<b>MARKING AND DOCUMENTATION</b>		P
5.1	Marking		P
5.1.1	General		P
	Equipment shall bear markings as specified in 5.1 and 5.2	The marking label is on the outer surface of the enclosure.	P
	Graphic symbols may be used and shall be in accordance with Annex C or IEC 60417 as applicable.	All used graphic symbols are in accordance with Annex C.	P
	Graphic symbols shall be explained in the documentation provided with the PCE.	The explanations are provided in the user manual.	P
5.1.2	Durability of markings	The labels were subjected to the permanence of marking	P
	Markings required by this clause to be located on the PCE shall remain clear and legible under conditions of NORMAL USE and resist the effects of cleaning agents specified by the manufacturer	After this test there was no damage to the labels. The marking on the labels did not fade. There was no curling or	P

IEC 62109-1			
Clause	Requirement – Test	Result – Remark	Verdict
		lifting of the label's edges.	
5.1.3	Identification		P
	The equipment shall, as a minimum, be permanently marked with:	See below.	P
	a) the name or trade mark of the manufacturer or supplier	See copy of marking plate.	P
	b) model number, name or other means to identify the equipment	See above.	P
	c) a serial number, code or other marking allowing identification of manufacturing location and the manufacturing batch or date within a three month time period.	See above.	P
5.1.4	Equipment ratings		P
	Unless otherwise specified in another part of IEC 62109, the following ratings, as applicable shall be marked on the equipment:	See below	P
	– input voltage, type of voltage (a.c. or d.c.), frequency, and max. continuous current for each input	See model list.	P
	– output voltage, type of voltage (a.c. or d.c.), frequency, max. continuous current, and for a.c. outputs, either the power or power factor for each output	See above.	P
	– the ingress protection (IP) rating as in 6.3 below	See clause 6.3	P
5.1.5	Fuse identification		P
	Marking shall be located adjacent to each fuse or fuseholder, or on the fuseholder, or in another location provided that it is obvious to which fuse the marking applies, giving the fuse current rating and where fuses of different voltage rating value could be fitted, the fuse voltage rating.	Marking on PCB near fuses.	P
	Where fuses with special fusing characteristics such as time delay or breaking capacity are necessary, the type shall also be indicated	See above.	P
	For fuses not located in operator access areas and for soldered-in fuses located in operator access areas, it is permitted to provide an unambiguous cross-reference (for example, F1, F2, etc.) to the servicing instructions which shall contain the relevant information.	See above.	P
5.1.6	Terminals, Connections, and Controls		P
	If necessary for safety, an indication shall be given of the purpose of Terminals, connectors, controls, and indicators, and their various positions, including any connections for coolant fluids such as water	Relevant symbol, indicator or information are available.	P

IEC 62109-1			
Clause	Requirement – Test	Result – Remark	Verdict
	and drainage. The symbols in Annex C may be used, and where there is insufficient space, symbol 9 of Annex C may be used.		
	Push-buttons and actuators of emergency stop devices, and indicator lamps used only to indicate a warning of danger or the need for urgent action shall be coloured red.	No such device.	N/A
	A multiple-voltage unit shall be marked to indicate the particular voltage for which it is set when shipped from the factory. The marking is allowed to be in the form of a paper tag or any other non-permanent material.		N/A
	A unit with d.c. terminals shall be plainly marked indicating the polarity of the connections, with:		P
	– the sign “+“ for positive and “-“, for negative; or	The “+” and “-“ marking provided adjacent to the PV input connectors.	P
	– a pictorial representation illustrating the proper polarity where the correct polarity can be unambiguously determined from the representation	No pictorial representation illustration used.	N/A
5.1.6.1	Protective Conductor Terminals		P
	The means of connection for the protective earthing conductor shall be marked with:		P
	– symbol 7 of Annex C; or	Symbol 7 of Table C.1 marked adjacent to the PE terminal.	P
	– the letters “PE“; or	See above.	N/A
	– the colour coding green-yellow.		P
5.1.7	Switches and circuit-breakers		P
	The on and off-positions of switches and circuits breakers shall be clearly marked. If a push-button switch is used as the power switch, symbols 10 and 16 of Annex C may be used to indicate the on-position, or symbols 11 and 17 to indicate the off-position, with the pair of symbols (10 and 16, or 11 and 17) close together.	The letter “ON” and “OFF” is clearly marked.	P
5.1.8	Class II Equipment	Class I Equipment.	N/A
	Equipment using Class II protective means throughout shall be marked with symbol 12 of Annex C. Equipment which is only partially protected by DOUBLE INSULATION or REINFORCED INSULATION shall not bear symbol 12 of Table Annex C.	See above.	N/A
	Where such equipment has provision for the connection of an earthing conductor for functional	See above.	N/A

IEC 62109-1			
Clause	Requirement – Test	Result – Remark	Verdict
	reasons (see 7.3.6.4) it shall be marked with symbol 6 of Annex C		
5.1.9	Terminal boxes for External Connections		N/A
	Where required by note 1 of Table 2 as a result of high temperatures of terminals or parts in the wiring compartment, there shall be a marking, visible beside the terminal before connection, of either:	Not used.	N/A
	a) the minimum temperature Rating and size of the cable to be connected to the TERMINALS; or		N/A
	b) a marking to warn the installer to consult the installation instruction. Symbol 9 of Table D-1 is an acceptable marking		N/A
5.2	Warning markings		P
5.2.1	Visibility and legibility requirements for warning markings		P
	Warning markings shall be legible, and shall have minimum dimensions as follows:		P
	– Printed symbols shall be at least 2,75 mm high		P
	– Printed text characters shall be at least 1.5 mm high and shall contrast in colour with the background		P
	– Symbols or text that are moulded, stamped or engraved in a material shall have a character height of at least 2,0 mm, and if not contrasting in colour from the background, shall have a depth or raised height of at least 0,5 mm.	No such symbols.	N/A
	If it is necessary to refer to the instruction manual to preserve the protection afforded by the equipment, the equipment shall be marked with symbol 9 of Annex C		P
	Symbol 9 of Annex C is not required to be used adjacent to symbols that are explained in the manual		P
5.2.2	Content for warning markings		P
5.2.2.1	Ungrounded heat sinks and similar parts		P
	An ungrounded heat sink or other part that may be mistaken for a grounded part and involves a risk of electric shock in accordance with 7.3 shall be marked with symbol 13 of Annex C, or equivalent. The marking may be on or adjacent to the heat sink and shall be clearly visible when the PCE is disassembled to the extent that a risk of contact with the heat sink exists.	Marked with symbol 13 of Table C.1.	P

<b>IEC 62109-1</b>			
Clause	Requirement – Test	Result – Remark	Verdict
5.2.2.2	Hot Surfaces		P
	A part of the PCE that exceeds the temperature limits specified in 4.3.2 shall be marked with symbol 14 of Annex C or equivalent.	Marked with symbol 14 of Table C.1.	P
5.2.2.3	Coolant		N/A
	A unit containing coolant that exceeds 70 °C shall be legibly marked externally where readily visible after installation with symbol 15 of Annex C. The documentation shall provide a warning regarding the risk of burns from hot coolant, and either:	Not used.	N/A
	a) statement that coolant system servicing is to be done only by SERVICE PERSONNEL, or		N/A
	b) instructions for safe venting, draining, or otherwise working on the cooling system, if these operations can be performed without OPERATOR access to HAZARDS internal to the equipment		N/A
5.2.2.4	Stored energy		P
	Where required by 7.3.9.2 or 7.4.2 the PCE shall be marked with Symbol 21 of Annex C and the time to discharge capacitors to safe voltage and energy levels shall accompany the symbol.	Marked with Symbol 21 of Table C.1 and the time to discharge capacitors to safe voltage and energy levels accompany the symbol.	P
5.2.2.5	Motor guarding		N/A
	Where required by 8.2 a marking shall be provided where it is visible to service personnel before removal of a guard, warning of the hazard and giving instructions for safe servicing (for example disconnection of the source before removing the guard).		N/A
5.2.3	Sonic hazard markings and instructions	No such hazard.	N/A
	If required by 10.2.1 a PCE shall:		N/A
	a) be marked to warn the operator of the sonic pressure hazard; or		N/A
	b) be provided with installation instructions that specify how the installer can ensure that the sound pressure level from equipment at its point of use after installation, will not reach a value, which could cause a hazard. These instructions shall include the measured sound pressure level, and shall identify readily available and practicable protective materials or measures which may be used.		N/A
5.2.4	Equipment with multiple sources of supply		P
	A PCE with connections for multiple energy	Marked with symbol 13 of	P



IEC 62109-1			
Clause	Requirement – Test	Result – Remark	Verdict
	sources shall be marked with symbol 13 of Annex C and the manual shall contain the information required in 5.3.4.	Annex C and explain in user manual.	
	The symbol shall be located on the outside of the unit or shall be prominently visible behind any cover giving access to hazardous parts.	See above.	P
5.2.5	Excessive touch current		P
	Where required by 7.3.6.3.7 the PCE shall be marked with symbol 15 of Annex C. See also 5.3.2 for information to be provided in the installation manual.	Marked with symbol 15 of Table C.1 and relevant information is provided in user's manual.	P
5.3	Documentation		P
5.3.1	General		P
	The documentation provided with the PCE shall provide the information needed for the safe operation, installation, and (where applicable) maintenance of the equipment. The documentation shall include the items required in 5.3.2 through 5.3.4, and the following:	All related informations provided in the user's maunal.	P
	a) explanations of equipment makings, including symbols used		P
	b) location and function of terminals and controls		P
	c) all ratings or specifications that are necessary to safely install and operate the PCE, including the following environmental ratings along with an explanation of their meaning and any resulting installation requirements:		P
	– ENVIRONMENTAL CATEGORY as per 6.1		P
	– WET LOCATIONS classification fort he intended external environment as per 6.1		P
	– POLLUTION DEGREE classification for the intended external environment as per 6.2		P
	– INGRESS PROTECTION rating as per 6.3		P
	– Ambient temperature and relative humidity ratings		P
	– MAXIMUM altitude rating		P
	– OVERVOLTAGE CATEGORY assigned to each input and output port as per 7.3.7.1.2, accompanied by guidance regarding how to ensure that the installation complies with the required overvoltage categories;		P
	d) a warning that when the photovoltaic array is exposed to light, it supplies a d.c. voltage to the		P

IEC 62109-1			
Clause	Requirement – Test	Result – Remark	Verdict
	PCE		
5.3.1.1	Language		P
	Instructions related to safety shall be in a language that is acceptable in the country where the equipment is to be installed.	Instruction related to safety is in English.	P
5.3.1.2	Format		P
	In general, the documentation must be provided in printed form and is to be delivered with the equipment.	The printed form is available and is delivered with the PCE.	P
	For equipment which requires the use of a computer for both installation and operation, documentation may be provided in electronic format without accompanying printed format.	See above.	N/A
5.3.2	Information related to installation		P
	The documentation shall include installation and where applicable, specific commissioning instructions and, if necessary for safety, warnings against hazards which could arise during installation or commissioning of the equipment. The information provided shall include:	All below related informations provided in the user's maunal.	P
	a) assembly, location, and mounting requirements:		P
	b) ratings and means of connection to each source of supply and any requirements related to wiring and external controls, colour coding of leads, disconnection means, or overcurrent protection needed, including instructions that the installation position shall not prevent access to the disconnection means;		P
	c) ratings and means of connection of any outputs from the PCE, and any requirements related to wiring and externals controls, colour coding of leads, or overcurrent protection needed;		P
	d) explanation of the pin-out of connectors for external connections, unless the connector is used for a standard purpose (e.g. RS 232)		P
	e) ventilation requirements;		P
	f) requirements for special services, for example cooling liquid;		N/A
	g) instructions and information relating to sound pressure level if required by 10.2.1;	No hazardous sound level.	P
	h) where required by 14.8.1.3, instructions for the adequate ventilation of the room or location in which PCE containing vented or valve-regulated batteries is located, to prevent the accumulation of hazardous gases;	No battery used in the PCE.	P

<b>IEC 62109-1</b>			
Clause	Requirement – Test	Result – Remark	Verdict
	i) tightening torque to be applied to wiring terminals;		P
	j) values of backfeed short-circuit currents available from the PCE on input and output conductors under fault conditions, if those currents exceed the max. rated current of the circuit, as per 4.4.4.6;	No backfeed current available.	P
	k) for each input to the PCE, the max value of short-circuit current available from the source, for which the PCE is designed; and		P
	l) compatibility with RCD and RCM;	RCMU built in PCE.	P
	m) instructions for protective earthing, including the information required by 7.3.6.3.7 if a second protective earthing conductor is to be installed:		P
	n) where required by 7.3.8, the installation instructions shall include the following or equivalent wording:		P
	“This product can cause a d.c. current in the external protective earthing conductor. Where a residual current-operated protective (RCD) or monitoring (RCM) device is used for protection in a case of direct or indirect contact, only an RCD or RCM of Type B is allowed on the supply side of this product.”		P
	o) for PCE intended to charge batteries, the battery nominal voltage rating, size, and type	PCE is not intended to charge battery.	P
	p) PV array configuration information, such as ratings, whether the array is to be grounded or floating, any external protection devices needed, etc.		P
5.3.3	Information related to operation		P
	Instructions for use shall include any operating instructions necessary to ensure safe operation, including the following, as applicable:	All related information provided in the user's manual.	P
	– Instructions for adjustment of controls including the effects of adjustment;		P
	– Instructions for interconnection to accessories and other equipment, including indication of suitable accessories, detachable parts and any special materials;		P
	– Warnings regarding the risk of burns from surfaces permitted to exceed the temperature limits of 4.3.2 and required operator actions to reduce the risk; and		P
	– Instructions, that if the equipment is used in a		P

IEC 62109-1			
Clause	Requirement – Test	Result – Remark	Verdict
	manner not specified by the manufacturer, the protection provided by the equipment may be impaired.		
5.3.4	Information related to maintenance		P
	Maintenance instructions shall include the following:	All related information provided in the service manual.	P
	– Intervals and instructions for any preventive maintenance that is required to maintain safety (for example air filter replacement or periodic re-tightening of terminals);		P
	– Instructions for accessing operator access areas, if any are present, including a warning not to enter other areas of the equipment;		P
	– Part numbers and instructions for obtaining any required operator replaceable parts;		P
	– Instructions for safe cleaning (if recommended)		P
	– Where there is more than one source of supply energizing the PCE, information shall be provided in the manual to indicate which disconnect device or devices are required to be operated in order to completely isolate the equipment.		P
5.3.4.1	Battery maintenance		N/A
	Where required by 14.8.5, the documentation shall include the applicable items from the following list of instructions regarding maintenance of batteries:	The PCE is Grid Interactive inverter without battery energy storage function.	N/A
	– Servicing of batteries should be performed or supervised by personnel knowledgeable about batteries and the required precautions		N/A
	– When replacing batteries, replace with the same type and number of batteries or battery packs		N/A
	– General instructions regarding removal and installation of batteries		N/A
	– CAUTION: Do not dispose of batteries in a fire. The batteries may explode.		N/A
	– CAUTION: Do not open or damage batteries. Released electrolyte is harmful to the skin and eyes. It may be toxic.		N/A
	– CAUTION: A battery can present a risk of electrical shock and high short-circuit current. The following precautions should be observed when working on batteries:		N/A

<b>IEC 62109-1</b>			
Clause	Requirement – Test	Result – Remark	Verdict
	a) Remove watches, rings, or other metal objects.		N/A
	b) Use tools with insulated handles.		N/A
	c) Wear rubber gloves and boots.		N/A
	d) Do not lay tools or metal parts on top of batteries		N/A
	e) Disconnect charging source prior to connecting or disconnecting battery terminals		N/A
	f) Determine if battery is inadvertently grounded. If inadvertently grounded, remove source from ground. Contact with any part of a grounded battery can result in electrical shock. The likelihood of such shock can be reduced if such grounds are removed during installation and maintenance (applicable to equipment and remote battery supplies not having a grounded supply circuit).		N/A
<b>6</b>	<b>ENVIRONMENTAL REQUIREMENTS AND CONDITIONS</b>		P
	The manufacturer shall rate the PCE for the following environmental conditions:		P
	– ENVIRONMENTAL CATEGORY, as in 6.1 below		P
	– Suitability for WET LOCATIONS or not		P
	– POLLUTION DEGREE rating in 6.2 below		P
	– INGRESS PROTECTION (IP) rating, as in 6.3 below		P
	– Ultraviolet (UV) exposure rating, as in 6.4 below		P
	– Ambient temperature and relative humidity ratings, as in 6.5 below		P
6.1	Environmental categories and minimum environmental conditions		P
6.1.1	Outdoor	For outdoor use.	P
6.1.2	Indoor, unconditioned	See above.	N/A
6.1.3	Indoor, conditioned	See above.	N/A
6.2	Pollution degree	PD 2 (inside), PD 3 (outside)	P
6.3	Ingress Protection	IP65.	P
6.4	UV exposure	The shelter is considered necessary for outdoor use. Anti-UV approved AC and DC connectors provided.	P
6.5	Temperature and humidity	Specified by manufacturer.	P
<b>7</b>	<b>PROTECTION AGAINST ELECTRIC SHOCK AND ENERGY HAZARDS</b>		P

IEC 62109-1			
Clause	Requirement – Test	Result – Remark	Verdict
7.1	General	The proper construction of PCE is available for protection against shock and energy hazards during installation, operation and maintenance under normal and single fault conditions.	P
7.2	Fault conditions	See subclause 4.4.	P
7.3	Protection against electric shock		P
7.3.1	General	Each circuit under evaluation is compliance.	P
7.3.2	Decisive voltage classification		P
7.3.2.1	Use of decisive voltage class (DVC)	See below	P
7.3.2.2	Limits of DVC (according table 6)	See subclause 7.3.2.1.	P
7.3.2.3	Short-terms limits of accessible voltages under fault conditions		P
7.3.2.4	Requirements for protection (according table 7)	For circuits evaluation information of PCE, refer to brief description of general product information on previous pages.	P
7.3.2.5	Connection to PELV and SELV circuits	DVC-A is classified for display and communication circuits.	P
7.3.2.6	Working voltage and DVC	See subclause 7.3.2.4.	P
7.3.2.6.1	General	See above.	P
7.3.2.6.2	AC working voltage (see Figure 2)		P
7.3.2.6.3	DC working voltage (see Figure 3)		P
7.3.2.6.4	Pulsating working voltage (see Figure 4)		P
7.3.3	protective separation	For protective separation evaluation information of PCE, refer to brief description of general product information on previous pages.	P
	Protective separation shall be achieved by:		P
	<ul style="list-style-type: none"> <li>▪ double or reinforced insulation, or</li> </ul>		P
	<ul style="list-style-type: none"> <li>▪ protective screening, i.e. by a conductive screen connected to earth by protective bonding in the PCE, or connected to the protective earth conductor itself, whereby the screen is separated from live parts by at least basic insulation, or</li> </ul>		P
	<ul style="list-style-type: none"> <li>▪ protective impedance comprising limitation of current per 7.3.5.3 and of discharged energy</li> </ul>		N/A

IEC 62109-1			
Clause	Requirement – Test	Result – Remark	Verdict
	per 7.3.5.4, or		
	▪ limitation of voltage according to 7.3.5.4.		N/A
	The protective separation shall be fully and effectively maintained under all conditions of intended use of the PCE		P
7.3.4	Protection against direct contact	Protection against electric shock by means of earthed metal enclosure. Any access to touch live parts is impossible.	P
7.3.4.1	General		P
	Protection against direct contact is employed to prevent persons from touching live parts that do not meet the requirements of 7.3.5 and shall be provided by one or more of the measure given in 7.3.4.2 (enclosures and barriers) and 7.3.4.3 (insulation).	See subclause 7.3.2.4.	P
	Open type sub-assemblies and devices do not require protective measures against direct contact but the instruction provided with the equipment must indicate that such measures must be provided in the end equipment or in the installation.		N/A
	Product intended for installation in CLOSED ELECTRICAL OPERATING AREAS, (see 3.9) need not have protective measures against direct contact, except as required by 7.3.4.2.4.		N/A
7.3.4.2	Protection by means of enclosures and barriers	Protection against electric shock by means of earthed metal enclosure.	P
	The following requirements apply where protection against contact with live parts is provided by enclosures or barriers, not by insulation in accordance with 7.3.4.3.		P
7.3.4.2.1	General		P
	Parts of enclosures and barriers that provide protection in accordance with these requirements shall not be removable without the use of a tool (see 7.3.4.2.3).		P
	Polymeric materials used to meet these requirements shall also meet the requirements of 13.6		N/A
7.3.4.2.2	Access probe criteria	Considered.	P
	Protection is considered to be achieved when the separation between the test probes and live parts, when tested as described below, is as follows:		P

<b>IEC 62109-1</b>			
Clause	Requirement – Test	Result – Remark	Verdict
	a) decisive voltage classification A, (DVC A) - the probe may touch the live parts	Considered.	P
	b) decisive voltage classification B, (DVC B) - the probe must not touch bare live parts	No DVC-B in the PCE	N/A
	c) decisive voltage classification C, (DVC C) – the probe must have adequate clearance to live parts, based on the clearance for Basic insulation using the recurring peak working voltage involved,	Considered.	P
7.3.4.2.3	Access probe tests		P
	Compliance with 7.3.4.2.1 is checked by all of the following:		P
	a) Inspection; and	Live parts are enclosed by the earthed metal enclosure and no openings.	P
	b) Tests with the test finger (Figure D.1) and test pin (Figure D.2) of 0E, the results of which shall comply with the requirements of 7.3.4.2.1 a), b), and c) as applicable. Probe tests are performed on openings in the enclosures after removal of parts that can be detached or opened by an operator without the use of a tool, including fuseholders, and with operator access doors and covers open. It is permitted to leave lamps in place for this test. Connectors that can be separated by an operator without use of a tool, shall also be tested during and after disconnection. Any movable parts are to be put in the most unfavourable position.	It is not possible to touch the hazardous live parts by the test finger and test pin.	P
	The test finger and the test pin are applied as above, without appreciable force, in every possible position, except that floor-standing equipment having a mass exceeding 40 kg is not tilted.		P
	Equipment intended for building-in or rack mounting, or for incorporation in larger equipment, is tested with access to the equipment limited according to the method of mounting detailed in the installation instructions.	Not intended for built-in or rack mounting.	N/A
	c) Openings preventing the entry of the jointed test finger ( Figure E-1 of 0E) during test b) above, are further tested by means of straight unjointed test finger (Figure E-3 of 0E), applied with a force of 30 N. If the unjointed finger enters, the test with the jointed finger is repeated except that the finger is applied using any necessary force up to 30 N.	No openings.	N/A
	d) In addition to a) – c) above, top surfaces of	No openings.	N/A



<b>IEC 62109-1</b>			
Clause	Requirement – Test	Result – Remark	Verdict
	enclosure shall be tested with the IP3X probe of IEC 60529. The test probe shall not penetrate the top surface of the enclosure when probed from the vertical direction $\pm 5^\circ$ only.		
7.3.4.2.4	Service access areas	It is not allowed to remove the cover during installation and maintenance when PCE is energized.	P
7.3.4.3	Protection by means of insulation of live parts	See subclause 7.3.2, 7.3.3 and 7.3.4.1.	P
	Where the requirements of 7.3.4.2 are not met, live parts shall be provided with insulation if:		P
	– their working voltage is greater than the maximum limit of decisive voltage class A, or		P
	– for a DVC A or B circuit, protective separation from adjacent circuit of DVC C is not provided (see note “†” under Table 7)		P
7.3.5	Protection in case of direct contact		P
7.3.5.1	General	See below.	P
	Protection in case of direct contact is required to ensure that contact with live parts does not produce a shock hazard.		P
	The protection against direct contact according to 7.3.4 is not required if the circuit contacted is separated from other circuits according to 7.3.2.3, and:		P
	– is of decisive voltage class A and complies with 7.3.5.2, or	Only DCV-A classified circuit can be touched directly, see also 7.3.5.2.	P
	– is provided with protective impedance according to 7.3.5.3, or		N/A
	– is limited in voltage according to 7.3.5.4		N/A
	In addition to the measures as given in 7.3.5.2 to 7.3.5.4, it shall be ensured that in the event of error or polarity reversal of connectors no voltages that exceed DVC A can be connected into a circuit with protective separation. This applies for example to plug-in-sub-assemblies or other plug-in devices which can be plugged-in without the use of a tool (key) or which are accessible without the use of a tool.		P
	Conformity is checked by visual inspection and trial insertion.		P
7.3.5.2	Protection using decisive voltage class A	Comm. port is considered as DVC-A which can be	P

IEC 62109-1			
Clause	Requirement – Test	Result – Remark	Verdict
		accessible and separated from DVC-C by double or reinforced insulation.	
7.3.5.3	Protection by means of protective impedance	This method not considered.	N/A
	Circuits and conductive parts do not require protection against direct contact if any connection to circuits of DVC-B or DVC-C is through protective impedance, and the accessible circuit or part is otherwise provided with protective separation from circuits of DVC-B or DVC-C according 7.3.3.		N/A
7.3.5.3.1	Limitation of current through protective impedance		N/A
	The current available through protective impedance to earth and between simultaneously accessible parts, measured at the accessible live parts, shall not exceed a value of 3,5 mA a.c. or 10 mA d.c. under normal and single-fault conditions.		N/A
7.3.5.3.2	Limitation of discharging energy through protective impedance		N/A
	The discharging energy available between simultaneously accessible parts protected by protective impedance shall not exceed the charging voltage and capacitance limits given in Table 9, which applies to both wet and dry locations, under normal and single fault conditions. Refer to figure 8.		
7.3.5.4	Protection by means of limited voltages	This method not considered.	N/A
	That portion of a circuit that has its voltage reduced to DVC-A by a voltage divider that complies with the following requirements, and that is otherwise provided with protective separation from circuits of DVC-B or DVC-C according to 7.3.3, does not require protection against direct contact.		N/A
	The voltage divider shall be designed so that under normal and single fault conditions, including faults in the voltage division circuit, the voltage across the output of the voltage divider does not exceed the limit for DVC-A.		N/A
	This type of protection shall not be used in case of protective class II or unearthed circuits, because it relies on protective earth being connected.		N/A
7.3.6	Protection against indirect contact		P
7.3.6.1	General		P
	Protection against indirect contact is required to prevent shock- hazardous current being accessible from conductive parts during an insulation failure. This protection shall comply with the requirements for protective class I (basic insulation plus protective earthing), class II (double or reinforced	The PCE is defined as protective class I.	P

<b>IEC 62109-1</b>			
Clause	Requirement – Test	Result – Remark	Verdict
	insulation) or class III (limitation of voltages)		
	That part of a PCE meets the requirements of 7.3.6.2 and 7.3.6.3 is defined as protective class I	The earthing metal enclosure is complied with Protective class I.	P
	That part of a PCE meets the requirements of 7.3.6.4 is defined as protective class II.	The circuit of communication is complied with Protective class II for accessible communication ports.	P
	That part of PCE which meets the requirements of decisive voltage class A and in which no hazardous voltages are derived, is defined as protective class III. No shock hazard is present in such circuits.		N/A
	Where protection against indirect contact is dependent on means provided during installation, the installation instructions shall provide details of the required means and shall indicate the associated hazards.		P
7.3.6.2	Insulation between live parts and accessible conductive parts	See subclaus 7.3.2.3, 7.3.7.4 and 7.3.7.5.	P
	Accessible conductive parts of equipment shall be separated from live parts by insulation meeting the requirements of Table 7 or by clearances as specified in 7.3.7.4 and creepages as specified in 7.3.7.5	The clearances specified in 7.3.7.4 and creepage specified in 7.3.7.5 are complied.	P
7.3.6.3	Protective class I – Protective bonding and earthing		P
7.3.6.3.1	General		P
	Equipment of protective class I shall be provided with protective earthing, and with protective bonding to ensure electrical contact between accessible conductive parts and the means of connection for the external protective earthing conductor, except bonding is not required for:	Suitable protective bonding provided.	P
	a) accessible conductive parts that are protected by one of the measures in 7.3.5.2 to 7.3.5.4, or	DVC-A classified circuit is considered.	P
	b) accessible conductive parts are separated from live parts of DVC-B or -C using double or reinforced insulation.	Display and communication circuits are separated from live parts used double or reinforced insulation.	P
7.3.6.3.2	Requirements for protective bonding	The cross-section of the protective bonding conductor is the same as that for the external protective earthing conductor.	P
	Electrical contact with the means of connection of the external protective earthing conductor shall be achieved by one or more of the following means:		P

IEC 62109-1			
Clause	Requirement – Test	Result – Remark	Verdict
	a) through direct metallic contact;	The connection of external protective earthing conductor is direct metal contact via a terminal with screw.	P
	b) through other conductive parts which are not removed when the PCE or sub-units are used as intended ;		P
	c) through a dedicated protective bonding conductor;	Protective earthing terminal used.	P
	d) through other metallic components of the PCE		N/A
	Where direct metallic contact is used and one or both of the parts involved is painted or coated, the paint or coating shall be removed in the area of contact, or reliably penetrated, to ensure metal to metal contact.		P
	For moving or removable parts, hinges or sliding contacts designed and maintained to have a low resistance are examples of acceptable means if they comply with the requirements of 7.3.6.3.3.		N/A
	Metal ducts of flexible or rigid construction and metallic sheaths shall not be used as protective bonding conductors, unless the device or material has been investigated as suitable for protective bonding purposes.		P
7.3.6.3.3	Rating of protective bonding	See below.	P
	Protective bonding shall withstand the highest thermal and dynamic stresses that can occur to the PCE item(s) concerned when they are subjected to a fault connecting live parts to accessible conductive parts. The protective bonding shall remain effective for as long as a fault to the accessible conductive parts persists or until an upstream protective device removes power from the part.	Suitable protective bonding used.	P
	Protective bonding shall meet following requirements:	See below.	P
	a) For PCE with an overcurrent protective device rating of 16 A or less, the impedance of the protective bonding means shall not exceed 0,1 $\Omega$ during or at the end of the test below.		N/A
	b) For PCE with an overcurrent protective device rating of more than 16 A, the voltage drop in the protective bonding test shall not exceed 2,5 V during or at the end of the test below.	Sub clause 7.3.6.3.5 is considered.	N/A
	As alternative to a) and b) the protective bonding may designed according to the requirements for the external protective earthing conductor in 7.3.6.3.5,	The cross-section of the protective bonding conductor is the same as that for the	P

<b>IEC 62109-1</b>			
Clause	Requirement – Test	Result – Remark	Verdict
	in which case no testing is required.	external protective earthing conductor.	
	The impedance of protective bonding means shall be checked by passing a test current through the bond for a period of time as specified below. The test current is based on the rating of the overcurrent protection for the equipment or part of the equipment under consideration, as follows:		N/A
	a) For pluggable equipment type A, the overcurrent protective device is that provided external to the equipment (for example, in the building wiring, in the mains plug or in an equipment rack);		N/A
	b) For pluggable equipment type B and fixed equipment, the maximum rating of the overcurrent protective device specified in the equipment installation instructions to be provided external to the equipment;		N/A
	c) For a circuit or part of the equipment for which an overcurrent protective device is provided as part of the equipment, the rating of the provided overcurrent device.		N/A
	Voltages are measured from the protective earthing terminal to all parts whose protective bonding means are being considered. The impedance of the protective earthing conductor is not included in the measurement. However, if the protective earthing conductor is supplied with the equipment, it is permitted to include the conductor in the test circuit but the measurement of the voltage drop is made only from the main protective earthing terminal to the accessible part required to be earthed.		N/A
	On equipment where the protective earth connection to a subassembly or to a separate unit is part of a cable that also supplies power to that subassembly or unit, the resistance of the protective bonding conductor in that cable is not included in the protective bond impedance measurements for the subassembly or separate unit, as shown in Figure 11. However, this option is only permitted if the cable is protected by a suitably rated protective device that takes into account the size of the conductor. Otherwise the impedance of the protective bonding conductor between the separate units is to be included, by measuring to the protective earthing terminal where the power source enters the first unit in the system, as shown in Figure 12.		N/A
7.3.6.3.3.1	Test current, duration, and acceptance criteria	The alternative of sub clause 7.3.6.3.5 was considered.	N/A

IEC 62109-1			
Clause	Requirement – Test	Result – Remark	Verdict
	The test current, duration of the test and acceptance criteria are as follows:	(see appended table 7.3.6.3.3)	N/A
	a) For PCE with an overcurrent protective device rating of 16 A or less, the test current is 200% of the overcurrent protective device rating, but not less than 32 A, applied for 120s. The impedance of the protective bonding means during and at the end of the test shall not exceed 0,1 Ω.		N/A
	b) For PCE with an overcurrent protective device rating of more than 16 A, the test current is 200% of the overcurrent protective device rating and the duration of the test is as shown in Table 10 below. The voltage drop in the protective bonding means, during and at the end of the test, shall not exceed 2,5 V.		N/A
	c) During and after the test, there shall be no melting, loosening, or other damage that would impair the effectiveness of the protective bonding means.		N/A
	The test current is derived from an a.c or d.c supply source, the output of which is not earthed.		N/A
	As an alternative to Table 10, where the time-current characteristic of the overcurrent protective device that limits the fault current in the protective bonding means is known because the device is either provided in the equipment or fully specified in the installation instructions, the test duration may be based on that specific device's time-current characteristic,. The tests are conducted for a duration corresponding to the 200% current value on the time-current characteristic.		N/A
7.3.6.3.4	Protective bonding impedance (routine test)		N/A
	If the continuity of the protective bonding is achieved at any point by a single means only (for example a single conductor or single fastener), or if the PCE is assembled at the installation location, then the impedance of the protective bonding shall also be tested as a routine test. The test shall be as in 7.3.6.3.3, except for the following:	The alternative of sub clause 7.3.6.3.5 was considered.	N/A
	<ul style="list-style-type: none"> <li>▪ the test current may be reduced to any convenient value greater than 10 A sufficient to allow measurement or calculation of the impedance of the protective bonding means:</li> </ul>		N/A
	<ul style="list-style-type: none"> <li>▪ the test duration may be reduced to no less than 2 s</li> </ul>		N/A

IEC 62109-1			
Clause	Requirement – Test	Result – Remark	Verdict
	For equipment subject to the type test in 7.3.6.3.3.1a), the impedance during the routine test shall not exceed 0,1Ω.		N/A
	For equipment subject to the type test in 7.3.6.3.3.1b) the impedance during the routine test shall not exceed 2,5 V divided by the test current required by 7.3.6.3.3.1b).		N/A
7.3.6.3.5	External protective earthing conductor		P
	A protective earthing conductor shall be connected at all times when power is supplied to PCE of protective class I. Unless local wiring regulations state otherwise, the protective earthing conductor cross-sectional area shall be determined from Table 11 or by calculation according to IEC 60364-5-54.	The external protective earthing conductor crosssectional is designed as half of phase conductors with same material. Related statement specified in manual.	P
	If the external protective earthing conductor is routed through a plug and socket or similar means of disconnection, it shall not be possible to disconnect it unless power is simultaneously removed from the part to be protected.		P
	The cross-sectional area of every external protective earthing conductor which does not form part of the supply cable or cable enclosure shall, in any case, be not less than:		P
	<ul style="list-style-type: none"> <li>▪ 2,5 mm<sup>2</sup> if mechanical protection is provided;</li> </ul>		N/A
	<ul style="list-style-type: none"> <li>▪ 4 mm<sup>2</sup> if mechanical protection is not provided.</li> </ul>	Related statement specified in user manual.	P
	For cord-connected equipment, provisions shall be made so that the external protective earthing conductor in the cord shall, in the case of failure of the strain-relief mechanism, be the last conductor to be interrupted.		N/A
7.3.6.3.6	Means of connection for the external protective earthing conductor		P
7.3.6.3.6.1	General		P
	<p>The means of connection for the external protective earthing conductor shall be located near the terminals for the respective live conductors. The means of connections shall be corrosion-resistant and shall be suitable for the connection of cables according to 7.3.6.3.5.</p> <p>The means of connection for the protective earthing conductor shall not be used as a part of the mechanical assembly of the equipment or for other connections.</p> <p>A separate means of connection shall be provided for each external protective earthing conductor.</p>	<p>The external protective earthing terminal block consist of other live conducts as AC connector for connecting PCE to the mains.</p> <p>Corrosion-resistant is considered for connection and bonding points.</p> <p>Separated earthing terminal be provided for protective earthing conductor was</p>	P

IEC 62109-1			
Clause	Requirement – Test	Result – Remark	Verdict
	Connection and bonding points shall be so designed that their current-carrying capacity is not impaired by mechanical, chemical, or electrochemical influences. Where enclosures and/or conductors of aluminium or aluminium alloys are used, particular attention should be given to the problems of electrolytic corrosion.	specified in user manual.	
	The means of connection for the protective earthing conductor shall be permanently marked with:		P
	<ul style="list-style-type: none"> <li>• symbol 7 of Annex C; or</li> </ul>	With the symbol 7 of Table C.1.	P
	<ul style="list-style-type: none"> <li>• the colour coding green-yellow</li> </ul>	The color coding of Green – yellow recommended.	P
	Marking shall not be done on easily changeable parts such as screws.		P
7.3.6.3.7	Touch current in case of failure of the protective earthing conductor		P
	The requirements of this sub-clause shall be satisfied to maintain safety in case of damage to or disconnection of the protective earthing conductor.		P
	For pluggable equipment type A, the touch current measured in accordance with 7.5.4 shall not exceed 3,5 mA a.c. or mA d.c.	(see appended table 7.3.6.3.7)	N/A
	For all other PCE, one or more of the following measure shall be applied, unless the touch current measured in accordance with 7.5.4 using the test network of IEC 60990 test figure 4 shall not exceed 3,5 mA a.c. or 10 mA d.c.	See appended table 7.5.4. In addition, the caution symbol 15 of Table C.1 provided on PCE and in manual.	P
	a) Permanently connected wiring, and:		P
	<ul style="list-style-type: none"> <li>• a cross-section of the protective earthing conductor of at least 10 mm<sup>2</sup> Cu or 16 mm<sup>2</sup> Al; or</li> </ul>		N/A
	<ul style="list-style-type: none"> <li>• automatic disconnection of the supply in case of discontinuity of the protective earthing conductor; or</li> </ul>		P
	<ul style="list-style-type: none"> <li>• provision of an additional terminal for a second protective earthing conductor of the same cross-sectional area as the original protective earthing conductor and installation instruction requiring a second protective earthing conductor to be installed or</li> </ul>		P
	b) Connection with an industrial connector according to IEC 60309 and a minimum protective earthing conductor cross-section of 2,5 mm <sup>2</sup> as part of a multi-conductor power		N/A



IEC 62109-1			
Clause	Requirement – Test	Result – Remark	Verdict
	cable. Adequate strain relief shall be provided.		
	In addition, the caution symbol 15 of Annex C shall be fixed to the product and the installation manual shall provide details of the protective earthing measures required in the installation as required in 5.3.2.		N/A
	When it is intended and allowed to connect two or more PCEs in parallel using one common PE conductor, the above touch current requirements apply to the maximum number of the PCEs to be connected in parallel, unless one of the measures in a)		N/A
	or b) above is used. The maximum number of parallel PCEs is used in the testing and has to be stated in the installation manual.		N/A
7.3.6.4	Protective Class II – Double or Reinforced Insulation	PCE is designed for protective class I.	N/A
	Equipment or parts of equipment designed for protective class II shall have insulation between live parts and accessible surfaces in accordance with 7.3.4.3. The following requirements also apply:		N/A
	<ul style="list-style-type: none"> <li>equipment designed to protective class II shall not have means of connection for the external protective earthing conductor. However this does not apply if the external protective earthing conductor is passed through the equipment to equipment series-connected beyond it. In the latter event, the external protective earthing conductor and its means for connection shall be insulated with basic insulation from the accessible surface of the equipment and from circuits that employ protective separation, extra-low voltage, protective impedance and limited discharging energy, according to 7.3.5. This basic insulation shall correspond to the rated voltage of the series-connected equipment;</li> </ul>		N/A
	<ul style="list-style-type: none"> <li>metal-encased equipment of protective class II may have provision on its enclosure for the connection of an equipotential bonding conductor;</li> </ul>		N/A
	<ul style="list-style-type: none"> <li>equipment of protective class II may have provision for the connection of an earthing conductor for functional reasons or for damping of overvoltages; it shall, however, be insulated as though it is a live part;</li> </ul>		N/A
	<ul style="list-style-type: none"> <li>equipment employing protective class II shall be marked according to 5.1.8.</li> </ul>		N/A

IEC 62109-1			
Clause	Requirement – Test	Result – Remark	Verdict
7.3.7	Insulation Including Clearance and Creepage Distance		P
7.3.7.1	General		P
	This subclause gives minimum requirements for insulation, based on the principles of IEC 60664.		P
	Manufacturing tolerances shall be taken into account during measurement of creepage, clearance, and insulation distance in the PCE.		P
	Insulation shall be selected after consideration of the following influences:		P
	<ul style="list-style-type: none"> <li>• pollution degree</li> </ul>	(see appended table 7.3.7.1.1)	P
	<ul style="list-style-type: none"> <li>• overvoltage category</li> </ul>	(see appended table 7.3.7.1.2)	P
	<ul style="list-style-type: none"> <li>• supply earthing system</li> </ul>	(see appended table 7.3.7.1.3)	P
	<ul style="list-style-type: none"> <li>• insulation voltage</li> </ul>	(see appended table 7.3.7.1.4)	P
	<ul style="list-style-type: none"> <li>• location of insulation</li> </ul>		P
	<ul style="list-style-type: none"> <li>• type of insulation</li> </ul>		P
	Compliance of insulation, creepage distances, and clearance distances, shall be verified by measurement or visual inspection, and the tests of 7.5.		P
7.3.7.1.3	Supply earthing systems	For TN system.	P
	Three basic types of earthing system are described in IEC 60364-1. They are:		P
	<ul style="list-style-type: none"> <li>• TN system: has one point directly earthed, the accessible conductive parts of the installation being connected to that point by protective conductors. Three types of TN systems, TN-C, TN-S and TN-C-S, are defined according to the arrangement of the neutral and protective conductor.</li> </ul>		P
	<ul style="list-style-type: none"> <li>• TT system: has one point directly earthed, the accessible conductive parts of the installation being connected to earth electrodes electrically independent of the earth electrodes of the power system;</li> </ul>		N/A
	<ul style="list-style-type: none"> <li>• IT system: has all live parts isolated from earth or one point connected to earth through an impedance, the accessible conductive parts of the installation being earthed independently or collectively to the earthing system.</li> </ul>		N/A

IEC 62109-1			
Clause	Requirement – Test	Result – Remark	Verdict
7.3.7.1.4	Insulation voltages	PV supply circuits: 6000V (VMAX PV: 1000Vd.c.) AC mains circuits: 4000V (Rated: 3~ 400Va.c.) Other circuits: 2500V (Rated: 230Va.c.)	P
	Table 12 makes use of the circuit system voltage and overvoltage category to define the impulse withstands voltage and the temporary overvoltage.		P
7.3.7.2	Insulation between a circuit and its surroundings		P
7.3.7.2.1	General	Considered.	P
7.3.7.2.2	Circuits connected directly to the mains	Clearances and solid insulation required according to the impulse voltage, temporary overvoltage, or working voltage, whichever gives the most severe requirement.	P
7.3.7.2.3	Circuits other than mains circuits	Clearances and solid insulation required according to the impulse voltage and recurring peak voltage.	P
7.3.7.2.4	Insulation between circuits	Clearances and solid insulation according to the higher impulse voltages. Creepages according of the higher r.m.s. working voltage.	P
7.3.7.3	Functional insulating		P
7.3.7.4	Clearance distances	(see appended table 7.3.7)	P
7.3.7.4.1	Determination	The max. insulation / impulse voltage: 6000V.	P
7.3.7.4.2	Electric field homogeneity	Not considered.	N/A
7.3.7.4.3	Clearance to conductive enclosures	Refer to subclause 7.3.7.4.1 and 13.7.	P
7.3.7.5	Creepage distances	(see appended table 7.3.7)	P
7.3.7.5.1	General		P
7.3.7.5.2	Voltage	The max. voltage: 400Vrms / 1000Vd.c	P
7.3.7.5.3	Materials	Insulating material group IIIb 175 > CTI ≥ 100 assumed.	P
7.3.7.6	Coating	Not used.	N/A
7.3.7.7	PWB spacings for functional insulating	Comply with 7.3.7.4 and 7.3.7.5.	N/A

<b>IEC 62109-1</b>			
Clause	Requirement – Test	Result – Remark	Verdict
7.3.7.8	Solid insulating	(see appended table 7.3.7)	P
7.3.7.8.1	General		P
7.3.7.8.2	Requirements for electrical withstand capability of solid insulation		P
7.3.7.8.2.1	Basic, supplemental, reinforced, and double insulation	Passed the impulse withstand voltage and a.c. or d.c. voltage tests. See appended table 7.5.1, 7.5.2 & 7.5.3. Note: No double or reinforced solid insulation used. No voltage stress on the insulation is greater than 1 kV/mm.	P
7.3.7.8.2.2	Functional insulation	Not used.	N/A
7.3.7.8.3	Thin sheet or tape material	See below.	P
7.3.7.8.3.1	General		P
7.3.7.8.3.2	Material thickness not less than 0,2 mm	Bobbin used in power transformer.	P
7.3.7.8.3.3	Material thickness less than 0,2 mm	Multi-layers mylar sheets provided between primary and secondary in main transformer.	P
7.3.7.8.3.4	Compliance	See subclause 7.3.7.8.3.2.	P
7.3.7.8.4	Printed wiring boards		P
7.3.7.8.4.1	General	Insulation between conductor layers in double-sided singlelayer PWBs meet the requirements of 7.3.7.8.1. Basic, supplementary, double and reinforced insulation meet the appropriate requirements of 7.3.7.8.2.1 or 7.3.7.8.2.2. Functional insulation in PWBs meet the requirements of 7.3.7.8.2.3.	P
7.3.7.8.4.2	Use of coating materials	No coating material used.	N/A
7.3.7.8.5	Wound components	No such wound components.	N/A
7.3.7.8.6	Potting materials	No potting materials used.	N/A
7.3.7.9	Insulation requirements above 30 kHz	Considered.	P
7.3.8	Residual Current-operated protective (RCD) or monitoring (RCM) device compatibility	Built-in RCM unit within the PCE.	N/A
	RCD and RCM are used to provide protection	Under normal and single-fault	N/A

IEC 62109-1			
Clause	Requirement – Test	Result – Remark	Verdict
	against insulation faults in some domestic and industrial installations, additional to that provided by the installed equipment.	conditions, the resulting d.c. component of the current in the protective earthing conductor does not exceed the d.c. current withstand requirements in IEC 60755 and IEC 62020 for RCD and RCM of type B.	
7.3.9	Capacitor discharge	(see appended table 7.3.9)	P
7.3.9.1	Operator access area		N/A
	Equipment shall be so designed that there is no risk of electric shock in operator access areas from charge stored on capacitors after disconnection of the PCE.		N/A
7.3.9.2	Service access areas		P
	Capacitors located behind panels that are removable for servicing, installation, or disconnection shall present no risk of electric shock or energy hazard from charge stored on capacitors after disconnection of the PCE.	The warning symbol 21 of Table C.1 and an indication of the discharge time is placed in a clearly visible position on the protective barrier to avoid unconsciousness contact.	P
7.4	Protection against energy hazards		P
7.4.1	Determination of hazardous energy level	There is no risk of energy hazard in operator access areas, protection of electrical shock by means of earthed metal enclosure.	P
	A hazardous energy level is considered to exist if		P
	a) The voltage is 2 V or more, and power available after 60 s exceeds 240 VA.		P
	b) The stored energy in a capacitor is at a voltage. U of 2 V or more, and the stored energy. E, calculated from the following equation, exceeds 20J:  $E = 0,5 CU^2$		P
7.4.2	Operator Access Areas		P
	Equipment shall be so designed that there is no risk of energy hazard in operator access areas from accessible circuits.	All hazardous energy parts were enclosed within the earthed metal enclosure.	P
7.4.3	Services Access Areas		P
7.5	Electrical tests related to shock hazard	(see appended table 7.5)	P
7.5.1	Impulse voltage test (type test)	See appended table 7.5.1. During the test no puncture, flashover, or sparkover	P

<b>IEC 62109-1</b>			
Clause	Requirement – Test	Result – Remark	Verdict
		occurs.	
7.5.2	Voltage test (dielectric strength test)	See below.	P
7.5.2.1	Purpose of test		P
7.5.2.2	Value and type of test voltage	(see appended table 7.5.2)	P
7.5.2.3	Humidity pre-conditioning	PCE is intended for WET LOCATIONS use.	P
7.5.2.4	Performing the voltage test	Refer to appended table 7.5.2.	P
7.5.2.5	Duration of the a.c. or d.c. voltage test	The full voltage is maintained for 60s.	P
7.5.2.6	Verification of the a.c. or d.c. voltage test	No electrical breakdown occurs during the test.	P
7.5.3	Partial discharge test	No double or reinforced solid insulation used. No voltage stress on the insulation is greater than 1 kV/mm.	N/A
7.5.4	Touch current measurement (type test)		P
	The touch current shall be measured if required by 7.3.6.3.7 and shall not be greater than 3.5 mA a.c. or 10 mA d.c. or special measures of protection as given in 7.3.6.3.7 are required.	(see appended table 7.3.6.3.7)	P
	For type tests on PCE for which wet locations requirements apply according to 6.1, the humidity pre-conditioning of 4.5 shall be performed immediately prior to the touch current test.	See above.	P
7.5.5	Equipment with multiple sources of supply		N/A
<b>8</b>	<b>PROTECTION AGAINST MECHANICAL HAZARDS</b>		P
8.1	General		P
	Operation shall not lead to a mechanical HAZARD in NORMAL CONDITION or SINGLE FAULT CONDITION. Edges, projections, corners, openings, guards, handles and the like, that are accessible to the operator shall be smooth and rounded so as not to cause injury during normal use of the equipment.	Edges, projections, corners, openings, guards, handles and the like, that are accessible to the OPERATOR are smooth and rounded.	P
	Conformity is checked as specified in 8.2 to 8.6.		P
8.2	Moving parts		N/A
	Moving parts shall not be able to crush, cut or pierce parts of the body of an OPERATOR likely to contact them, nor severely pinch the OPERATOR's skin. Hazardous moving parts of equipment, that is moving parts which have the potential to cause injury, shall be so arranged, enclosed or guarded as to provide adequate protection against the risk		N/A

<b>IEC 62109-1</b>			
Clause	Requirement – Test	Result – Remark	Verdict
	of personal injury.		
8.2.1	Protection of service persons		P
	Protection shall be provided such that unintentional contact with hazardous moving parts is unlikely during servicing operations. If a guard over a hazardous moving part may need to be removed for servicing, the marking of symbol 15 of Table D-1 shall be applied on or near the guard.	Barrier and the marking of symbol 15 of Table C.1 is provided for service persons.	P
8.3	Stability		N/A
	Equipment and assemblies of equipment not secured to the building structure before operation shall be physically stable in NORMAL USE.	The PCE is wall mounted equipment.	N/A
8.4	Provisions for lifting and carrying		N/A
	If carrying handles or grips are fitted to, or supplied with, the equipment, they shall be capable of withstanding a force of four times the weight of the equipment.	Not handles or grips	N/A
	Equipment or parts having a mass of 18 kg or more shall be provided with a means for lifting and carrying or directions shall be given in the manufacturer's documentation.	Less than 18kg	N/A
8.5	Wall mounting		P
	Mounting brackets on equipment intended to be mounted on a wall or ceiling shall withstand a force of four times the weight of the equipment.	Mounting brackets and wall construction for installation condition are specified in installation manual. Mounting brackets withstand a force of four times the weight of the equipment.	P
8.6	Expelled parts		N/A
	Equipment shall contain or limit the energy of parts that could cause a HAZARD if expelled in the event of a fault.	No such parts.	N/A
<b>9</b>	<b>PROTECTION AGAINST FIRE HAZARDS</b>		P
9.1	Resistance to fire		P
	This subclause specifies requirements intended to reduce the risk of ignition and the spread of flame, both within the equipment and to the outside, by the appropriate use of materials and components and by suitable construction.	Suitable and appropriate materials, components and construction are used to reduce the risk of ignition and the spread of flame.	P
9.1.1	Reducing the risk of ignition and spread of flame		P
	For equipment or a portion of equipment, there are two alternative methods of providing protection against ignition and spread of flame that could		P

IEC 62109-1			
Clause	Requirement – Test	Result – Remark	Verdict
	affect materials, wiring, wound components and electronic components such as integrated circuits, transistors, thyristors, diodes, resistors and capacitors.		
9.1.2	Conditions for a fire enclosure		P
	A FIRE ENCLOSURE is required for equipment or parts of equipment for which Method 2 is not fully applied and complied with.	A FIRE ENCLOSURE is required for equipment or parts of equipment.	P
9.1.2.1	Parts requiring a fire enclosure		P
	Except where Method 2 is used, or as permitted in 9.1.2.2, the following are considered to have a risk of ignition and, therefore, require a FIRE ENCLOSURE:		P
	– components in PRIMARY CIRCUITS		P
	– components in SECONDARY CIRCUITS supplied by power sources which exceed the limits for a LIMITED POWER SOURCE as specified in 9.2;		P
	– components in SECONDARY CIRCUITS supplied by a LIMITED POWER SOURCE as specified in 9.2, but not mounted on a material of FLAMMABILITY CLASS V-1;		P
	– components within a power supply unit or assembly having a limited power output complying with the criteria for a LIMITED POWER SOURCE as specified in 9.2, including overcurrent protective devices, limiting impedances, regulating networks and wiring, up to the point where the LIMITED POWER SOURCE output criteria are met;		P
	– components having unenclosed arcing parts, such as open switch and relay contacts and commutators, in a circuit at HAZARDOUS VOLTAGE or at a HAZARDOUS ENERGY LEVEL; and		P
	– insulated wiring, except as permitted in 9.1.2.2.		P
9.1.2.2	Parts not requiring a fire enclosure	See above.	N/A
9.1.3	Materials requirements for protection against fire hazard		P
9.1.3.1	General		P
	ENCLOSURES, components and other parts shall be so constructed, or shall make use of such materials, that the propagation of fire is limited.	Metal enclosure provided.	P
9.1.3.2	Materials for fire enclosures		P



<b>IEC 62109-1</b>			
Clause	Requirement – Test	Result – Remark	Verdict
	If an enclosure material is not classified as specified below, a test may be performed on the final enclosure or part of the enclosure, in which case the material shall additionally be subjected to periodic SAMPLE testing.	Metal enclosure provided.	P
9.1.3.3	Materials for components and other parts outside fire enclosures		P
	Except as otherwise noted below, materials for components and other parts (including MECHANICAL ENCLOSURES, ELECTRICAL ENCLOSURES and DECORATIVE PARTS); located outside FIRE ENCLOSURES, shall be of FLAMMABILITY CLASS HB.	FLAMMABILITY CLASS HB or better used.	P
9.1.3.4	Materials for components and other parts inside fire enclosures	FLAMMABILITY CLASS V- 2 or better used.	P
9.1.3.5	Materials for air filter assemblies	No such materials.	N/A
9.1.4	Openings in fire enclosures		P
9.1.4.1	General	No openings in fire enclosures.	P
	For equipment that is intended to be used or installed in more than one orientation as specified in the product documentation, the following requirements apply in each orientation.		P
	These requirements are in addition to those in the following sections:		P
	– 7.3.4, Protection against direct contact;		P
	– 7.4, Protection against energy hazards;		P
	– 13.5, Openings in enclosures		P
9.1.4.2	Side openings treated as bottom openings	See above.	N/A
9.1.4.3	Openings in the bottom of a fire enclosure	See above.	N/A
	The bottom of a FIRE ENCLOSURE or individual barriers, shall provide protection against emission of flaming or molten material under all internal parts, including partially enclosed components or assemblies, for which Method 2 of 9.1.1 has not been fully applied and complied with.		N/A
9.1.4.4	Equipment for use in a CLOSED ELECTRICAL OPERATING AREA		N/A
	The requirements of 9.1.4.3 do not apply to FIXED EQUIPMENT intended only for use in a CLOSED ELECTRICAL OPERATING AREA and to be mounted on a concrete floor or other non-combustible surface. Such equipment shall be marked as follows:		N/A

<b>IEC 62109-1</b>			
Clause	Requirement – Test	Result – Remark	Verdict
	WARNING: FIRE HAZARD SUITABLE FOR MOUNTING ON CONCRETE OR OTHER NON-COMBUSTIBLE SURFACE ONLY		N/A
9.1.4.5	Doors or covers in fire enclosures		P
9.1.4.6	Additional requirements for openings in transportable equipment	PCE not for transportable equipment.	N/A
9.2	LIMITED POWER SOURCES	Not applied.	N/A
9.2.1	General		N/A
9.2.2	Limited power source tests	(see appended table 9.2)	N/A
9.3	Short-circuit and overcurrent protection		P
9.3.1	General		P
	The PCE shall not present a hazard, under short-circuit or overcurrent conditions at any port, including phase-to-phase, phase-to-earth and phase-to-neutral, and adequate information shall be provided to allow proper selection of external wiring and external protective devices.	No overcurrent hazards was presented by short circuits and overloads tests. Refer to sub-clause 4.4.4.	P
9.3.2	Protection against short-circuits and overcurrents shall be provided for all input circuits, and for output circuits that do not comply with the requirements for limited power sources in 9.2, except for circuits in which no overcurrent hazard is presented by short-circuits and overloads.		P
9.3.3	Protective devices provided or specified shall have adequate breaking capacity to interrupt the maximum short circuit current specified for the port to which they are connected. If protection that is provided integral to the PCE for an input port is not rated for the short-circuit current of the circuit in which it is used, the installation instructions shall specify that an upstream protective device, rated for the prospective short-circuit current of that port, shall be used to provide backup protection.	Upstream protective device for backup protection is specified in the installation manual.	P
<b>10</b>	<b>PROTECTION AGAINST SONIC PRESSURE HAZARDS</b>		P
10.1	General		P
	The equipment shall provide protection against the effect of sonic pressure. Conformity tests are carried out if the equipment is likely to cause such HAZARDS.		P
10.2	Sonic pressure and Sound level		P
10.2.1	Hazardous Noise Levels	Sound pressure level is lower than 80dB.	P
<b>11</b>	<b>PROTECTION AGAINST LIQUID HAZARDS</b>		N/A
11.1	Liquid Containment, Pressure and Leakage	No liquid contained in this	N/A

<b>IEC 62109-1</b>			
Clause	Requirement – Test	Result – Remark	Verdict
		system, and energy storage battery used.	
	The liquid containment system components shall be compatible with the liquid to be used.		N/A
	There shall be no leakage of liquid onto live parts as a result of:		N/A
	a) Normal operation, including condensation;		N/A
	b) Servicing of the equipment; or		N/A
	c) Inadvertent loosening or detachment of hoses or other cooling system parts over time.		N/A
11.2	Fluid pressure and leakage		N/A
11.2.1	Maximum pressure		N/A
11.2.2	Leakage from parts		N/A
11.2.3	Overpressure safety device		N/A
11.3	Oil and grease		N/A
<b>12</b>	<b>CHEMICAL HAZARDS</b>		N/A
12.1	General	No chemical Hazards.	N/A
<b>13</b>	<b>PHYSICAL REQUIREMENTS</b>		P
13.1	Handles and manual controls	It shall not be possible to fix them in wrong position if this might result in a hazard.	P
	Handles, knobs, grips, levers and the like shall be reliably fixed so that they will not work loose in normal use, if this might result in a hazard. Sealing compounds and the like, other than self-hardening resins, shall not be used to prevent loosening. If handles, knobs and the like are used to indicate the position of switches or similar components, it shall not be possible to fix them in a wrong position if this might result in hazard.		P
13.1.1	Adjustable controls	No such controls.	N/A
13.2	Securing of parts	Screws, nuts, washers, springs or similar parts are secured so as to withstand mechanical stresses occurring	P
13.3	Provisions for external connections		P
13.3.1	General	Appropriate provisions for external connections applied.	P
13.3.2	Connection to an a.c. Mains supply		P
13.3.2.1	General	Terminals provided for permanent connection to the PV supply.	P

IEC 62109-1			
Clause	Requirement – Test	Result – Remark	Verdict
	For safe and reliable connection to a MAINS supply, equipment shall be provided with one of the following:		P
	– terminals or leads or a non-detachable power supply cord for permanent connection to the supply; or		P
	– a non-detachable power supply cord for connection to the supply by means of a plug		N/A
	– an appliance inlet for connection of a detachable power supply cord; or		N/A
	– a mains plug that is part of direct plug-in equipment as in 13.3.8		N/A
13.3.2.2	Permanently connected equipment	A set of terminals as specified in 13.3.3 for external connection of supply cords.	P
13.3.2.3	Appliance inlets		N/A
13.3.2.4	Power supply cord	Not provided, but technical requirements provided in user manual.	N/A
13.3.2.5	Cord anchorages and strain relief	No power supply cords provided.	N/A
	For equipment with a non-detachable power supply cord, a cord anchorage shall be supplied such that:		N/A
	– the connecting points of the cord conductors are relieved from strain; and		N/A
	– the outer covering of the cord is protected from abrasion.		N/A
13.3.2.6	Protection against mechanical damage	No power supply cords provided, however plastic inlet bushings provided ready for use.	N/A
13.3.3	Wiring terminals for connection of external conductors		P
13.3.3.1	Wiring terminals	Terminals for power supply cords connection by means of screws.	P
13.3.3.2	Screw terminals	Screws and nuts which clamp external supply conductors have a thread conforming to ISO 261 or ISO 262.	P
13.3.3.3	Wiring terminal sizes	The terminals meet the temperature rise test of 4.3 when connected using wire sizes as specified in the	P

IEC 62109-1			
Clause	Requirement – Test	Result – Remark	Verdict
		documentation or in Table 24.	
13.3.3.4	Wiring terminal design	Lug terminals applied, and the cable lug clamped by nut.	P
13.3.3.5	Grouping of wiring terminals	Terminals located in proximity to each other.	P
13.3.3.6	Stranded wire	Lug terminals applied.	P
13.3.4	Supply wiring space	Lug terminals applied, and the cable lug is clamped by nut without the risk of damage to the conductors or their insulation.	P
13.3.5	Wire bending space for wires 10 mm <sup>2</sup> and greater	Considered.	P
13.3.6	Disconnection from supply sources	Disconnect devices provided.	P
13.3.7	Connectors, plugs and sockets	The misconnection is unlikely for PV or DC connectors.	P
13.3.8	Direct plug-in equipment	Not direct plug-in use.	N/A
13.4	Internal wiring and connections		P
13.4.1	General	The insulation, conductors and routing of all wires of the equipment is suitable for the electrical, mechanical, thermal and environmental conditions of use.	P
13.4.2	Routing	Wires are routed away from sharp edges, screw threads, burrs, fins, moving parts, drawers, and similar parts, which could abrade the wire insulation.	P
13.4.3	Colour coding	The green/yellow color coding wire only used for protective earthing conductor.	P
13.4.4	Splices and connections	All splices and connections are mechanically adequate secure and provided electrical continuity. The likelihood of loose is impossible.	P
13.4.5	Interconnections between parts of the PCE	The communication cable only used for servicing, no any physical damage or mechanical damage likely.	P
13.5	Openings in enclosures		N/A
13.5.1	Top and side openings		N/A

<b>IEC 62109-1</b>			
Clause	Requirement – Test	Result – Remark	Verdict
	Openings in the top and sides of ENCLOSURES shall be so located or constructed that it is unlikely that objects will enter the openings and create hazards by contacting bare conductive parts.		N/A
13.6	Polymeric Materials		P
13.6.1	General	See below.	P
13.6.1.1	Thermal index or capability	Appropriate electrical, mechanical, thermal and flammability degree polymeric materials provided.	P
13.6.2	Polymers serving as enclosures or barriers preventing access to hazards	Metal enclosure used.	N/A
13.6.2.1	Stress relief test	See above.	N/A
13.6.3	Polymers serving as solid insulation	See below.	P
13.6.3.1	Resistance to arcing		P
13.6.4	UV resistance	Metal enclosure provided.	N/A
	Polymeric parts of an OUTDOOR ENCLOSURE required for compliance with this standard shall be sufficiently resistance to degradation by ultra-violet (UV) radiation		N/A
13.7	Mechanical resistance to deflection, impact, or drop		P
13.7.1	General	See below.	P
13.7.2	250-N deflection test for metal enclosures	A steady force of 250 N applied for 5 s, after test no hazards occurred.	P
13.7.3	7-J impact test for polymeric enclosures	Impact test applied on the display screen cover.	P
13.7.4	Drop test	Not for hand - held, direct plug - in, or transportable equipment.	N/A
13.8	Thickness requirements for metal enclosures		P
13.8.1	General		P
13.8.2	Cast metal		N/A
13.8.3	Sheet metal		N/A
<b>14</b>	<b>COMPONENTS</b>		P
14.1	General	(see appended table 14)	P
	Where safety is involved, components shall be used in accordance with their specified RATINGS unless a specific exception is made. They shall conform to one of the following:		P

IEC 62109-1			
Clause	Requirement – Test	Result – Remark	Verdict
	a) applicable safety requirements of a relevant IEC standard. Conformity with other requirements of the component standard is not required. If necessary for the application, components shall be subjected to the test of this standard, except that it is not necessary to carry out identical or equivalent tests already performed to check conformity with the component standard;		P
	b) the requirements of this standard and, where necessary for the application, any additional applicable safety requirements of the relevant IEC component standard;		P
	c) if there is no relevant IEC standard, the requirements of this standard;		P
	d) applicable safety requirements of a non-IEC standard which are at least as high as those of the applicable IEC standard, provided that the component has been approved to the non-IEC standard by a recognized testing authority.		P
	Components such as optocouplers, capacitors, transformers, and relays connected across basic, supplemental, reinforced, or double insulation shall comply with the requirements applicable for the grade of insulation being bridged, and if not previously certified to the applicable component safety standard shall be subjected to the voltage test of 7.5.2 as routine test.		P
14.2	Motor Over temperature Protection		N/A
	Motors which, when stopped or prevented from starting (see 4.4.4.3), would present an electric shock HAZARD, a temperature HAZARD, or a fire HAZARD, shall be protected by an over temperature or thermal protection device meeting the requirements of 14.3.		N/A
14.3	Over temperature protection devices	Approved overtemperature protective devices used and for which appropriate rating was selected for use and do not operate in normal use. For overtemperature protection test or evaluation see appended table 4.4.4.	P
14.4	Fuse holders	Fuse holders with fuses are not intended to be replaceable by an OPERATOR.	N/A
14.5	MAINS voltage selecting devices	No such devices.	N/A

IEC 62109-1			
Clause	Requirement – Test	Result – Remark	Verdict
14.6	Printed circuit boards		P
	Printed circuit boards shall be made of material with a flammability classification of V-1 of IEC 60707 or better.	PCB materials with a flammability classification of V-1 or better used.	P
	This requirement does not apply to thin-film flexible printed circuit boards that contain only circuits powered from limited power sources meeting the requirements of 9.2.		P
	Conformity of the flammability RATING is checked by inspection of data on the materials. Alternatively, conformity is checked by performing the V-1 tests specified in IEC 60707 on three samples of the relevant parts.		P
14.7	Circuits or components used as transient overvoltage limiting devices		N/A
	If control of transient overvoltage is employed in the equipment, any overvoltage limiting component or circuit shall be tested with the applicable impulse withstand voltage of Table 7-10 using the test method from 7.5.1 except 10 positive and 10 negative impulses are to be applied and may be spaced up to 1 min apart.	No such components.	N/A
14.8	Batteries		N/A
	Equipment containing batteries shall be designed to reduce the risk of fire, explosion and chemical leaks under normal conditions and after a single fault in the equipment including a fault in circuitry within the equipment battery pack.		N/A
14.8.1	Battery Enclosure Ventilation		N/A
14.8.1.1	Ventilation requirements		N/A
14.8.1.2	Ventilation testing		N/A
14.8.1.3	Ventilation instructions		N/A
14.8.2	Battery Mounting		N/A
	Compliance is verified by the application of the force to the battery's mounting surface. The test force is to be increased gradually so as to reach the required value in 5 to 10 s, and is to be maintained at that value for 1 min. A non-metallic rack or tray shall be tested at the highest normal condition operating temperature.		N/A
14.8.3	Electrolyte spillage		N/A
	Battery trays and cabinets shall have an electrolyte-resistant coating.		N/A
	The ENCLOSURE or compartment housing a VENTED BATTERY shall be constructed so that		N/A



IEC 62109-1			
Clause	Requirement – Test	Result – Remark	Verdict
	spillage or leakage of the electrolyte from one battery will be contained within the ENCLOSURE and be prevented from:		
	a) reaching the PCE outer surfaces that can be contacted by the USER		N/A
	b) contaminating adjacent electrical components or materials; and		N/A
	c) bridging required electrical distances		N/A
14.8.4	Battery Connections		N/A
	Reverse battery connection of the terminals shall be prevented if reverse connection could result in a hazard within the meaning of this Standard		N/A
14.8.5	Battery maintenance instructions		N/A
	The information and instructions listed in 5.3.4.1 shall be included in the operator manual for equipment in which battery maintenance is performed by the operator, or in the service manual if battery maintenance is to be performed by service personnel only.		N/A
14.8.6	Battery accessibility and maintainability		N/A
	Battery terminals and connectors shall be accessible for maintenance with the correct TOOLS. Batteries with liquid electrolyte, requiring maintained shall be so located that the battery cell caps are accessible for electrolyte tests and readjusting of electrolyte levels.		N/A
15	Software and firmware performing safety functions	Single fault safe compliance. Failures evaluation and risk analysis were performed by means of fault simulation or single fault conditions. (refer to subclause of 4.4.4).	P

IEC 62109-1			
Clause	Requirement – Test	Result – Remark	Verdict

4.2.2.6/4.7	TABLE: : electrical data in normal condition							P
Type	U (V) DC	I (A) DC	P (W) DC	U (V) grid	I (A) AC	F(Hz)AC	P (W) AC	
Mode: EVVO 1100TL-AV								
Inverter	52.5	6.4	335.3	230.0	1.8	50.0	305.0	
	114.0	10.3	1169.5	230.4	4.8	50.0	1106.3	
	496.8	0.7	338.0	230.0	1.4	50.0	316.5	
	52.4	6.6	315.5	230.0	1.4	60.0	315.5	
	114.0	10.2	1167.1	230.4	5.3	60.0	1102.0	
	496.8	0.9	422.8	230.1	2.0	60.0	399.9	
Mode: EVVO 2200TL-AV								
Inverter	51.2	3.9	198.4	230.0	0.8	50.0	177.8	
	198.8	11.5	2295.4	230.9	9.5	50.0	2194.9	
	498.8	0.4	197.6	229.8	0.8	50.0	183.1	
	52.6	3.8	197.8	230.0	0.8	60.0	179.0	
	198.3	11.5	2289.2	230.9	10.3	60.0	2181.5	
	496.8	0.4	193.4	229.8	0.8	60.0	178.9	
Mode: EVVO 3200TL-AV								
Inverter	51.3	2.6	131.9	229.9	0.6	50.0	114.2	
	303.2	11.2	3403.6	231.1	14.2	50.0	3275.3	
	548.8	0.3	145.6	229.8	0.7	50.0	126.9	
	51.3	2.6	131.9	229.9	0.6	60.0	114.1	
	299.0	11.4	3403.3	230.1	15.4	60.0	3262.1	
	548.9	0.3	149.2	229.7	0.7	60.0	130.3	
Supplementary information:								

IEC 62109-1			
Clause	Requirement – Test	Result – Remark	Verdict

<b>4.3</b>	<b>TABLE: Heating Test</b>				P	
	test voltage (V) .....	See below			—	
	t1 (°C).....	See below			—	
	t2 (°C) .....	See below			—	
Thermocouple Locations		Max. temperature measured (°C)				Limit, (°C)
Conditions:		PV input				--
Supplied Voltage [Vd.c.]	300	300	500	500	--	
Ambient [°C]	45.0	60	45.0	60.0	-	
Display button	48.0	67.74	46.9	67.55	75	
PV terminal	46.9	66.59	46.0	64.12	90	
Switch handle	46.9	66.64	44.9	65.04	85	
Output terminal	46.9	66.87	46.9	67.57	90	
EUT side temperature	53.8	67.51	52.0	63.51	70	
Heat sink temperature	52.4	67.67	59.8	68.49	70	
Output power line	61.0	77.77	59.8	77.58	105	
Switch body	60.4	82.58	58.7	81.98	85	
PV power line	56.3	76.92	53.5	75.98	105	
QP5	85.7	115.21	64.6	88.18	130	
DP1	85.6	107.26	75.2	99.46	-	
QP4	79.8	101.05	80.2	98.89	130	
QP2	81.6	104.01	82.1	102.18	130	
ARM board chip	59.3	79.50	57.2	79.27	-	
QP3	77.9	98.86	78.5	97.05	130	
QP1	80.5	102.84	81.1	101.05	130	
CP34	62.6	82.94	59.0	81.23	125	
Heat sink NTC	71.3	94.74	67.7	89.98	-	
DC common mode inductor	73.5	90.50	65.2	87.73	130	
CP30	68.1	87.50	62.7	84.13	90	
RYP1(ring temperature)	70.5	82.46	66.5	84.89	-	
Boost inductor	92.1	108.75	72.7	98.00	130	
INV1 inductor	101.4	111.00	101.4	107.05	130	
INV2 inductor	100.9	110.99	100.9	105.85	130	
HLP1(ring temperature)	73.5	83.90	72.4	84.89	-	
Relay (ring temperature)	71.5	84.92	69.8	84.21	-	
Drive optocoupler (ring temperature)	70.5	84.94	67.9	83.88	-	
CP47	76.0	88.78	75.9	86.23	90	
LP2	75.1	89.53	75.2	90.44	110	
BUS capacitor	74.1	90.17	69.1	89.59	105	
CP46	61.0	86.03	63.6	83.71	90	
AC common mode inductor	86.7	96.77	87.8	98.96	130	
Main DSP	81.0	99.05	79.1	98.60	-	
Transformer core	64.9	85.63	64.4	86.13	130	
Transformer coil	66.9	87.59	66.7	88.21	130	
CP52	67.1	84.85	66.2	84.84	90	
RVP4	65.5	83.11	64.3	82.98	-	

<b>IEC 62109-1</b>			
Clause	Requirement – Test	Result – Remark	Verdict

Supplementary information:

<b>TABLE: Heating test, resistance method</b>						--	
<b>Test voltage (V)</b> .....						--	—
<b>Ambient, t<sub>1</sub> (°C)</b> .....						--	—
<b>Ambient, t<sub>2</sub> (°C)</b> .....						--	—
Temperature rise of winding	R <sub>1</sub> (Ω)	R <sub>2</sub> (Ω)	ΔT (K)	Max. dT (K)	Insulation class		
--	--	--	--	--	--		

Supplementary information:

IEC 62109-1			
Clause	Requirement – Test	Result – Remark	Verdict

4.4		TABLE: fault condition tests					P
		ambient temperature (°C) ..... : 25°C, if not stated otherwise					—
No.	component No.	fault	test voltage (V)	test time	fuse No.	fuse current (A)	result
1	DP1 Pin1-2	S-C	PV: 500Vdc AC output: 230Vac	5min	--	--	PEC shut down immediately. Disconnect from the grid. After fault removed, it cannot be work normally. QP2, QP6 damaged. No hazard.
2	QP5 PinC-G	S-C	PV: 500Vdc AC output: 230Vac	5min	--	--	PEC shut down immediately. Disconnect from the grid. After fault removed, it cannot be work normally. R17, R15, QP8, UP3 damaged. No hazard.
3	ECP2	S-C	PV: 500Vdc AC output: 230Vac	5min	--	--	PEC shut down immediately. Disconnect from the grid. After fault removed, it cannot be work normally. QP2, QP6 damaged. No hazard.
4	RP5	O-C	PV: 500Vdc AC output: 230Vac	5min	--	--	Shut down immediately. No hazard No damaged.
5	QP1 Pin G-C	S-C	PV: 500Vdc AC output: 230Vac	5min	--	--	PEC shut down immediately. Disconnect from the grid. After fault removed, it cannot be work normally. UP1, UP4, QP1, QP2, QP3, QP4, RP7, RP8, RP13 damaged. No hazard.
6	QP1 Pin C- E	S-C	PV: 500Vdc AC output: 230Vac	5min	--	--	PEC shut down immediately. Disconnect from the grid. After fault removed, it cannot be work normally. QP1, QP2, QP3, QP4 damaged. No hazard..
7	QP2 Pin G-C	S-C	PV: 500Vdc AC output: 230Vac	5min	--	--	PEC shut down immediately. Disconnect from the grid. After fault removed, it cannot be work normally. UP1, UP4, QP1, QP2, QP3, QP4, RP10, RP11, RP14 damaged. No hazard.

IEC 62109-1							
Clause	Requirement – Test			Result – Remark			Verdict
8	QP2 Pin C-E	S-C	PV: 500Vdc AC output: 230Vac	5min	--	--	PEC shut down immediately. Disconnect from the grid. After fault removed, it cannot be work normally QP1, QP2, QP3, QP4 damaged. No hazard.
9	RP57	O-C	PV: 500Vdc AC output: 230Vac	5min	--	--	It can be work normally. No damaged. No hazard.
10	RP85	O-C	PV: 500Vdc AC output: 230Vac	5min	--	--	PEC protected immediately. Disconnect from the grid. No damaged. No hazard.
11	RYP3 Pin3-4	S-C	PV: 500Vdc AC output: 230Vac	5min	--	--	PEC protected immediately. Disconnect from the grid. No damaged. No hazard.
12	RYP2 Pin3-4	S-C	PV: 500Vdc AC output: 230Vac	5min	--	--	PEC protected immediately. Disconnect from the grid. No damaged. No hazard.
13	RYP4 Pin3-4	S-C	PV: 500Vdc AC output: 230Vac	5min	--	--	PEC protected immediately. Disconnect from the grid. No damaged. No hazard.
14	RYP5 Pin3-4	S-C	PV: 500Vdc AC output: 230Vac	5min	--	--	PEC protected immediately. Disconnect from the grid. No damaged. No hazard.
15	QP17 Pin C-E	S-C	PV: 500Vdc AC output: 230Vac	5min	--	--	It can be work normally. No damaged. No hazard.
16	QP17 Pin C	O-C	PV: 500Vdc AC output: 230Vac	5min	--	--	PEC protected immediately. Report ID55, No damaged. No hazard.
17	LP2 Pin 1-3	S-C	PV: 500Vdc AC output: 230Vac	5min	--	--	PEC protected immediately. Report ID20, No damaged. No hazard.
18	RP88	O-C	PV: 500Vdc AC output: 230Vac	5min	--	--	PEC protected immediately. Report ID01, No damaged. No hazard.
19	ECP63	S-C	PV: 500Vdc AC output: 230Vac	5min	--	--	PEC protected immediately. Disconnect from the grid. After fault removed, it can be work normally. No damaged. No hazard.
20	ECP68	S-C	PV: 500Vdc AC output: 230Vac	5min	--	--	PEC protected immediately. Disconnect from the grid. After fault removed, it can be work normally. No damaged. No hazard.
21	ECP72	S-C	PV: 500Vdc AC output: 230Vac	5min	--	--	PEC protected immediately. Disconnect from the grid. After fault removed, it can be work normally. No damaged. No hazard.

IEC 62109-1							
Clause	Requirement – Test					Result – Remark	Verdict
22	ECP22	S-C	PV: 500Vdc AC output: 230Vac	5min	--	--	PEC protected immediately. Disconnect from the grid. After fault removed, it can be work normally. No damaged. No hazard.
23	UP9 Pin4 和TXP1 Pin4	S-C	PV: 500Vdc AC output: 230Vac	5min	--	--	PEC protected immediately. Disconnect from the grid. After fault removed, it can be work normally. No damaged. No hazard.
24	ECP12	S-C	PV: 500Vdc AC output: 230Vac	5min	--	--	PEC protected immediately. Disconnect from the grid. After fault removed, it can be work normally. No damaged. No hazard.
25	ECP21	S-C	PV: 500Vdc AC output: 230Vac	5min	--	--	PEC protected immediately. Disconnect from the grid. After fault removed, it can be work normally. No damaged. No hazard.
26	U13 Pin 8	O-C	PV: 500Vdc AC output: 230Vac	5min	--	--	PEC protected immediately. No damaged. No hazard.
27	C21	S-C	PV: 500Vdc AC output: 230Vac	5min	--	--	PEC protected immediately. The display is not lit. No damaged. No hazard.
28	XL2 Pin1- 3	S-C	PV: 500Vdc AC output: 230Vac	5min	--	--	PEC protected immediately. The display is not lit. No damaged. No hazard.
29	EC4	S-C	PV: 500Vdc AC output: 230Vac	5min	--	--	PEC protected immediately. The display is not lit. No damaged. No hazard.
30	U5 Pin2-3	S-C	PV: 500Vdc AC output: 230Vac	5min	--	--	PEC protected immediately. Report ID05, No damaged. No hazard.
31	RC62	S-C	PV: 500Vdc AC output: 230Vac	5min	--	--	PEC protected immediately. Report ID20, No damaged. No hazard.
32	CC76	S-C	PV: 500Vdc AC output: 230Vac	5min	--	--	PEC protected immediately. Report ID20, No damaged. No hazard.
33	U1 Pin2-3	S-C	PV: 500Vdc AC output: 230Vac	5min	--	--	PEC protected immediately. Report ID02, No damaged. No hazard.
34	U1 Pin5-6	S-C	PV: 500Vdc AC output: 230Vac	5min	--	--	PEC protected immediately. Report ID55, No damaged. No hazard.
35	U6 Pin2-3	S-C	PV: 500Vdc AC output: 230Vac	5min	--	--	PEC protected immediately. Report ID23, No damaged. No hazard.
36	UC3 pin5-6	S-C	PV: 500Vdc AC output: 230Vac	5min	--	--	PEC protected immediately. Report ID17, ID18, No damaged. No hazard.

IEC 62109-1							
Clause	Requirement – Test				Result – Remark		Verdict
37	U2 Pin8-9	S-C	PV: 500Vdc AC output: 230Vac	5min	--	--	It can be work normally. No damaged. No hazard.
38	XLC1 PIN1-3	S-C	PV: 500Vdc AC output: 230Vac	5min	--	--	PEC protected immediately. No damaged. No hazard.
39	PV + and -	Reverse connection	PV: 500Vdc AC output: 230Vac	5min	--	--	The PCE cannot work. After fault removed, it can be work normally. No damaged. No hazard.
40	AC L and N	Reverse connection	PV: 500Vdc AC output: 230Vac	5min	--	--	It can be work normally. No damaged. No hazard.
41	AC output	S-C	PV: 500Vdc AC output: 230Vac	5min	--	--	PEC protected immediately. Report ID65, No damaged. No hazard.
supplementary information							
See technical documentation.							

7.3.6.3.3	TABLE: protective equipotential bonding ;				P
Measured between:	Test current (A)	Voltage drop (V)	Resistance (mΩ)	result	
AC connector earthing pin to furthest point of earthed metal enclosure	40	0.32	8	Pass	
supplementary information					

7.3.6.3.7	TABLE: touch current measurement			P
Measured between:	Measured (mA)	Limit (mA)	Comments/conditions	
At metal enclosure	AC 2.24	AC 3.5 / DC 10	PE disconnected	
Supplementary information: Max. MPPT Voltage supply input, 1.1Un AC mains connection.				



IEC 62109-1			
Clause	Requirement – Test	Result – Remark	Verdict

7.3.7	TABLE: clearance and creepage distance measurements						P
clearance cl and creepage distance dcr at / of:	Up (V)	U r.m.s. (V)	required cl (mm)	cl (mm)	required dcr (mm)	dcr (mm)	
DVC-C circuit to Communication circuit: RI	4000	550Vdc 230Vac	5.5	6.21	5.5	6.21	
PV supply circuits to metal chassis: BI	4000	550Vdc 230Vac	3.0	6.42	3.0	6.42	
AC mains circuits to metal chassis: BI	4000	550Vdc 230Vac	3.0	4.30	3.0	4.30	
PV supply circuits earth : BI	4000	550Vdc 230Vac	3.0	6.42	3.0	6.42	
AC mains circuits to earth : BI	4000	550Vdc 230Vac	3.0	4.30	3.0	4.30	
Circuits Definition:							
Communication Circuits: DVC-A			PV Circuits: DVC-C				
AC mains / Grid Circuits: DVC-C							
Supplementary information:							
PV supply circuits = O.V.C II, AC mains circuits = O.V.C. III, DC Power Supply Voltage = O.V.C II. PD = PD2 (inside) (IP65), MG = IIIa/b, Altitude = 2000m							

7.3.7	TABLE: distance through insulation measurement				P
distance through insulation di at/of:	U r.m.s. (V)	test voltage (V)	required di (mm)	di (mm)	
Bobbin in transformer (BI)	DC 1100V or AC 230/400V	2120	0.2	1.0	
Optical coupler <sup>1)</sup> (RI)	DC 1100V or AC 230/400V	4240	0.4	0.6	
Note(s): <sup>1)</sup> Certificated components.					

IEC 62109-1			
Clause	Requirement – Test	Result – Remark	Verdict

7.5	<b>TABLE: electric strength measurements, impulse voltage test and partial discharge test</b>			P
test voltage applied between:	test voltage (V)	impulse withstand voltage (V)	partial discharge extinction voltage (V)	result
Input to metal chassis (BI)	2120	6000	--	Pass
Output to metal chassis (BI)	2120	6000	--	Pass
Input to Comm. part (DI)	4240	8000	--	Pass
Output to Comm. part (DI)	4240	8000	--	Pass

9.2	<b>TABLE: Limited power sources</b>	N/A
-----	-------------------------------------	-----

Circuit output tested:						
Note: Measured Uoc (V) with all load circuits disconnected:						
Components	Sample No.	Uoc (V)	I <sub>sc</sub> (A)		VA	
			Meas.	Limit	Meas.	Limit
--	--	--	--	--	--	--
supplementary information:						
Sc=Short circuit, Oc=Open circuit						

IEC 62109-1					
Clause	Requirement – Test		Result – Remark		Verdict
<b>14</b>	<b>TABLE: list of critical components</b>				<b>P</b>
object/part No.	manufacturer/ trademark	type/model	technical data	standard	mark(s) of conformity <sup>1)</sup>
<b>EUT</b>					
Metal enclosure	--	--	Min.1.2mm thickness	--	--
Plastic cover (LCD screen)	JINGMEN GORUN TECHNOLOGY CO LTD	HF70	80°C, V-0, min. 3.0mm thickness	UL 94 UL 746C	UL E305163
PV connector	Amphenol Industrial operations	Helios H4series	1000Vdc, 40A, Max. 90°C, IP68	DIN V VDE V 0126-3/12.2006	TUV R50157783
(Alternative)	Phoenix Contact GmbH & Co.kg	PV-FT-CF-C; PV-FT-CM-C	1000Vdc, 40A, Max.85°C, IP65	EN 50521	TUV R60029159
(Alternative)	Stäubli Electrical Connectors Ltd.	PV-KST4/xy PV-KBT4/xy PV-ADSP4/z PV-ADBP4/z	1000Vdc, 39A, Max. 90°C, IP68	EN 50521	TUV R60028286
(Alternative)	Amphenol Industrial Operations	H4 Light	1000Vdc, 39A, Max. 90°C, IP68	IEC 62852:2014 EN 62852:2015	TUV Rheinland Report No: 50388083 0004
DC switch	Santon Switchgear Ltd	XBE+3210/2-D	1000V dc, 16A dc, Max.85°C	EN 60947-3	KEMA 2199573.01
AC terminal	Kunshan GRantech Electronics and technology Co., Ltd.	PVPM3251- 8GS02-BF	V-0, 250V, 25A, Max.100°C, IP68	DIN EN 61984	TUV SUD B 13 01 82966 001
(Alternative)	Shanghai Vaconn Electronic Technology Co. Ltd	VPAC07EW-3S	V-0, 300V, 30A,Max.90°C, IP67	DIN EN 61984	TUV R 50235418
All PCB	All	All accepted	Min.105°C, min. V-0, CTI≥175	UL 796	UL
Plastic sheet for Transistors (QP5,DP1,QP1, QP2,QP3,QP4)	All	65Mn,PBT	130°C, V-0,	--	--
<b>Main board</b>					
Y Capacitor (CP52,CP45,CP 51,CP44)	TDK (Zhuhai FTZ) Co., Ltd.	B32021A3103M Z1	10nF, 300V, Max.110°C	EN 60384-14	VDE 40018909

IEC 62109-1			
Clause	Requirement – Test	Result – Remark	Verdict

14	TABLE: list of critical components					P
object/part No.	manufacturer/ trademark	type/model	technical data	standard	mark(s) of conformity <sup>1)</sup>	
(Alternative)	Shantou High- New Technology Dev. Zone Songtian Enterprise Co., Ltd	CE series	10nF, 250V, Max.125°C	IEC 60384-14	VDE 40025748	
(Alternative)	Samwha capacitor Co.,Ltd	SD series	Y2 10nF 250VAC	EN 60384-14 IEC 60384-14	VDE 40015804	
Y Capacitor (CP34,CP27,CP 35,CP28,CP64, CP74)	Shantou HighNew Technology Dev. Zone Songtian Enterprise Co.,Ltd	CD series	4.7nF, 400V, Max.125°C	IEC 60384-14	VDE 40025754	
(Alternative)	Samwha capacitor Co.,Ltd	SD series	Y1 4.7nF 400VAC Max.125°C	EN 60384-14 IEC 60384-14	VDE 40015804	
(Alternative)	TDK Co., Ltd.,	CD series	Y1 4.7nF 400VAC Max.125°C	EN 60384-14 IEC 60384-14	VDE 40017931	
X Capacitor (CP46)	EPCOS (Zhuhai FTZ) Co., Ltd.,	B32924C3225K N1	2.2µf,305V,Max. 110°C	IEC 60384-14	VDE 40010694	
(Alternative)	XiaMen FARATRONIC Co.,Ltd	MKP62 series	2.2µf,305V,Max. 110°C	IEC 60384-14	VDE 40000358	
Varistor (RV1, RV2, RV3, RV4)	THINKING ELECTRONIC INDUSTRIAL CO., LTD	TVR14751KSY	465VAC, 615VDC, Imax:4.5kA, Max.125°C	IEC 61051- 1:2007-04	VDE 1669500- 4790-0002	
(Alternative)	TDK (ZHUHAI FTZ) CO., LTD.	B722*	460VAC 615VDC 100J	UL 1449	UL E321126	
BUS-Capacitor (EVVO 2700TL- AV, EVVO 3000TL-AV, EVVO 3200TL- AV ECP1, ECP2, ECP5)	nichicon Co., Ltd.	LGN2L471MEL ANH	470µf, 550V, Max.105°C	IEC/EN 62109-1 IEC/EN 62109-2	Tested within apparatus	
(Alternative)	Capxon electronic Co., Ltd.	UL471M550P7	470µf, 550V, Max.105°C	IEC/EN 62109-1 IEC/EN 62109-2	Tested within apparatus	

IEC 62109-1			
Clause	Requirement – Test	Result – Remark	Verdict

14	TABLE: list of critical components					P
object/part No.	manufacturer/ trademark	type/model	technical data	standard	mark(s) of conformity <sup>1)</sup>	
(Alternative)	Sam young electronics Co., Ltd.	TLC550VS470	470µf, 550V, Max.105°C	IEC/EN 62109-1 IEC/EN 62109-2	Tested within apparatus	
BUS-Capacitor (EVVO 1100TL-AV, EVVO 1600TL-AV, EVVO 2200TL-AV ECP1, ECP2)	nichicon Co., Ltd.	LGX2H471MEL C58	470µf, 500V, Max.105°C	IEC/EN 62109-1 IEC/EN 62109-2	Tested within apparatus	
(Alternative)	Lelon electronics	LSK471M2H	470µf, 500V, Max.105°C	IEC/EN 62109-1 IEC/EN 62109-2	Tested within apparatus	
(Alternative)	Sam young electronics Co., Ltd.	TLC500VS470	470µf, 500V, Max.105°C	IEC/EN 62109-1 IEC/EN 62109-2	Tested within apparatus	
IGBT (QP1, QP2, QP3, QP4, QP5)	Fairchild Semiconductor Corporation	FGA40T65SHD	650V, 40A, Max.175°C	IEC/EN 62109-1 IEC/EN 62109-2	Tested within apparatus	
(Alternative)	Fairchild Semiconductor Corporation	FGH40T65SHD	650V, 40A, Max.175°C	IEC/EN 62109-1 IEC/EN 62109-2	Tested within apparatus	
(Alternative)	Fairchild Semiconductor Corporation	FGH60T65SHD	650V, 60A, Max.175°C	IEC/EN 62109-1 IEC/EN 62109-2	Tested within apparatus	
(Alternative)	ST Semiconductor Corporation	STGWT40H65D FB	650V, 40A, Max.175°C	IEC/EN 62109-1 IEC/EN 62109-2	Tested within apparatus	
(Alternative)	ST Semiconductor Corporation	STGWT60H65D FB	650V, 60A, Max.175°C	IEC/EN 62109-1 IEC/EN 62109-2	Tested within apparatus	
Boost inductor	HUIZHOU BAOHUI ELECTRONICS TECHNOLOGY CO., LTD.	SH-L034	883µH, 130°C Class H	IEC/EN 62109-1 IEC/EN 62109-2	Tested within apparatus	
-TUBE	SHENZHEN WAHCHANGW EI INDUSTRIAL CO LTD	SGS-25	200°C	ANSI/UL 1441	UL E233804	
-Winding	SHANGHAI ASIA PACIFIC ELECTRIC CO LTD	EIW EI/AIW	180°C 220°C	UL 1446	UL E214423	
(Alternative)	DONG GUAN YIDA INDUSTRIAL	EIW EI/AIW	180°C 220°C	UL 1446	UL E344055	

IEC 62109-1			
Clause	Requirement – Test	Result – Remark	Verdict

14	TABLE: list of critical components					P
object/part No.	manufacturer/ trademark	type/model	technical data	standard	mark(s) of conformity <sup>1)</sup>	
	CO LTD					
(Alternative)	TONGLING JINGDA SPECIAL MAGNET WIRE CO LTD	QZY-2/180 QZY/XY-2/200	180°C 220°C	UL 1446	UL E223994	
(Alternative)	PACIFIC ELECTRIC WIRE & CABLE (SHENZHEN) CO LTD	PEWH EIAI/U	180°C 220°C	UL 1446	UL E201757	
INV inductor (EVVO 2700TL- AV, EVVO 3000TL-AV, EVVO 3200TL- AV)	HUIZHOU BAOHUI ELECTRONICS TECHNOLOGY CO., LTD.	SH-L032	676µH, 130°C Class H	IEC/EN 62109-1 IEC/EN 62109-2	Tested within apparatus	
-Winding	SHANGHAI ASIA PACIFIC ELECTRIC CO LTD	EIW EI/AIW	180°C 220°C	UL 1446	UL E214423	
(Alternative)	DONG GUAN YIDA INDUSTRIAL CO LTD	EIW EI/AIW	180°C 220°C	UL 1446	UL E344055	
(Alternative)	TONGLING JINGDA SPECIAL MAGNET WIRE CO LTD	QZY-2/180 QZY/XY-2/200	180°C 220°C	UL 1446	UL E223994	
-TUBE	SHENZHEN WAHCHANGW EI INDUSTRIAL CO LTD	SGS-25	200°C	ANSI/UL 1441	UL E233804	
INV inductor (EVVO 1100TL- AV, EVVO 1600TL-AV, EVVO 2200TL- AV)	HUIZHOU BAOHUI ELECTRONICS TECHNOLOGY CO., LTD.	SH-L039	998µH, 130°C Class H	IEC/EN 62109-1 IEC/EN 62109-2	Tested within apparatus	
-Winding	SHANGHAI ASIA PACIFIC ELECTRIC CO LTD	EIW EI/AIW	180°C 220°C	UL 1446	UL E214423	

IEC 62109-1			
Clause	Requirement – Test	Result – Remark	Verdict

14	TABLE: list of critical components					P
object/part No.	manufacturer/ trademark	type/model	technical data	standard	mark(s) of conformity <sup>1)</sup>	
(Alternative)	DONG GUAN YIDA INDUSTRIAL CO LTD	EIW EI/AIW	180°C 220°C	UL 1446	UL E344055	
(Alternative)	TONGLING JINGDA SPECIAL MAGNET WIRE CO LTD	QZY-2/180 QZY/XY-2/200	180°C 220°C	UL 1446	UL E223994	
(Alternative)	PACIFIC ELECTRIC WIRE & CABLE (SHENZHEN) CO LTD	PEWH EIAI/U	180°C 220°C	UL 1446	UL E201757	
-TUBE	SHENZHEN WAHCHANGW EI INDUSTRIAL CO LTD	SGS-25	200°C	ANSI/UL 1441	UL E233804	
AC filter inductor	HUIZHOU BAOHUI ELECTRONICS TECHNOLOGY CO., LTD.	SH-L041	130°C Class H	IEC/EN 62109-1 IEC/EN 62109-2	Tested within apparatus	
-Winding	SHANGHAI ASIA PACIFIC ELECTRIC CO LTD	EIW EI/AIW	180°C 220°C	UL 1446	UL E214423	
(Alternative)	DONG GUAN YIDA INDUSTRIAL CO LTD	EIW EI/AIW	180°C 220°C	UL 1446	UL E344055	
(Alternative)	TONGLING JINGDA SPECIAL MAGNET WIRE CO LTD	QZY-2/180 QZY/XY-2/200	180°C 220°C	UL 1446	UL E223994	
-TAPE	JINGJIANG YAHUA PRESSURE SENSITIVE GLUE CO LTD	CT-280B	130C	UL 510A	UL E165111	

IEC 62109-1					
Clause	Requirement – Test			Result – Remark	Verdict
DC filter inductor	HUIZHOU BAOHUI ELECTRONICS TECHNOLOGY CO.,LTD	SH-L041	130°C Class H	IEC/EN 62109-1 IEC/EN 62109-2	Tested within apparatus
-Winding	SHANGHAI ASIA PACIFIC ELECTRIC CO LTD	EIW EI/AIW	180°C 220°C	UL 1446	UL E214423
(Alternative)	DONG GUAN YIDA INDUSTRIAL CO LTD	EIW EI/AIW	180°C 220°C	UL 1446	UL E344055
(Alternative)	TONGLING JINGDA SPECIAL MAGNET WIRE CO LTD	QZY-2/180 QZY/XY-2/200	180°C 220°C	UL 1446	UL E223994
-TAPE	JINGJIANG YAHUA PRESSURE SENSITIVE GLUE CO LTD	CT-280B	130C	UL 510A	UL E165111
Relay (RYP2, RYP3, RYP4, RYP5)	Panasonic Corporation	ALFG2PF12	31A,250VAC,12 VDC,85°C	VDE 0435	VDE 40023067
(Alternative)	Xiamen Hongfa Electroacoustics Co., Ltd.	HF161F-W/12-HT	31A,250VAC,12 VDC,85°C	VDE 0435	VDE 40031410
(Alternative)	Panasonic Corporation	ALFG2PF121	33A,277VAC,12 VDC, Max.85°C	VDE 0435	VDE 40023067
(Alternative)	Xiamen Hong fa Electroacoustics Co., Ltd.	HF161F-W/12-HT(477)	33A,277VAC,12 VDC, Max.85°C	VDE 0435	VDE 40031410
(Alternative)	Dongguan Churod Electronics Co., Ltd.	CHFN-V-112HA2F	Max.35A,277VAC,12VDC, Max.85°C	EN 61810-1:2008	TUV R50220099
Transformer (TXP1)	HUIZHOU BAOHUI ELECTRONICS TECHNOLOGY CO., LTD.	SH-T013	110°C	IEC/EN 62109-1 IEC/EN 62109-2	Tested within apparatus
- Bobbin	SUMITOMO BAKELITE CO LTD	PM-9820	150°C	UL 746C	UL E41429
- Insulation tape	JINGJIANG	CT-	130°C	UL 510A	UL E165111



IEC 62109-1					
Clause	Requirement – Test	Result – Remark		Verdict	
	YAHUA PRESSURE SENSITIVE GLUE CO LTD				
-Winding	SHANGHAI ASIA PACIFIC ELECTRIC CO LTD	UEW-U UEW/NY	130°C 155°C	UL 1446	UL E214423
(Alternative)	DONG GUAN YIDA INDUSTRIAL CO LTD	UEW/130 UEW/155	130°C 155°C	UL 1446	UL E344055
(Alternative)	PACIFIC ELECTRIC WIRE & CABLE (SHENZHEN) CO LTD	UEW/U UEWN/U	130°C 155°C220°C	UL 1446	UL E201757
Optocoupler (UP1, UP2, UP3, UP4, UP5)	Fairchild Semiconductor Pte Ltd	FOD3120(- ;S;T;TS)(-;D)V	Di ≥ 0.4mm, Internall di ≥ 4.0mm, External di ≥ 7.0mm, AC 5000V, 110°C	EN 60747-5-5	VDE 40018398
(Alternative)	Toshiba Corporation Semicon. CO LTD	TLP350/TLP352	Di ≥ 0.4mm, Internall di ≥ 4.0mm, External di ≥ 7.0mm, AC 5000V, 110°C	EN 60747-5-2	VDE 40011913
1) an asterisk indicates a mark which assures the agreed level of surveillance					

**List of test equipment used:**

No.	Equipment name	Manufacture	Serial No.	Calibration Data	Usage
1	Solar IV simulator	Kewell	BZ-EP-L002	--	√
2	Solar IV simulator	Chroma	BZ-EP-L039	--	√
3	Programmable ac load	QunLing	BZ-EP-L003	--	√
4	Power analyzer	HIOKI	BZ-EP-L005	2020/02/26	√
5	Oscilloscope	Tektronix	BZ-EP-L016	2020/02/26	√
6	Heating Recoder	Agilent	BZ-EP-L021	2019/11/01	√
7	Hi-Pot & IR tester	Chroma	BZ-EP-L022	2019/10/31	√
8	Noise meter	TES	BZ-EP-L023	2020/3/10	√
9	Spring Hammer	BLS	BZ-EP-L034	2020/3/17	√
10	Digital Caliper	CHUANLIANG	BZ-SFT-L003	2019/10/31	√
11	Testing Finger B	AODESAI	BZ-SFT-L011	2019/11/1	√
12	DC Electronic Load	itech	BZ-SFT-L028	2019/10/31	√
13	Pull and push	HANDPI	BZ-SFT-L045	2019/10/31	√
14	Electronic Scale	/	BZ-SFT-L087	2020/2/25	√
15	Thermostat	Hading	BZ-KKX-L003	2019/10/31	√
16	Sand and dust chamber	Gongwen	BZ-KKX-L010	2019/6/3	√
17	Strong flushing test device	Gongwen	BZ-KKX-L009	2019/10/31	√
18	Surge generator	/	BZ-EMC-L015	2019/6/12	√
19	Stop watch	TF	BZ-SFT-L068	2019/06/19	√
20	Ground Resistance Tester	AINUO	BZ-SFT-L033	2019.10.31	√
21	Leakage current test network	Anbiao	BZ-SFT-L111	2020/03/02	√

- End of Test Report -



<b>TEST REPORT</b> <b>IEC 62109-2</b> <b>Safety of Power Converter for use in Photovoltaic Power Systems</b> <b>Part 2: Particular requirements for inverters</b>	
<b>Report Number.</b> .....	BL-SZ19B0347-B01 attachment 1
<b>Date of issue</b> .....	Nov. 09, 2019
<b>Total number of pages</b> .....	25
<b>Name of Testing Laboratory preparing the Report</b> .....	Shenzhen BALUN Technology Co., Ltd
<b>Applicant's name</b> .....	EVOLVE ENERGY GROUP CO., LIMITED
<b>Address</b> .....	RM 702, 7/F FU FAI COMM CTR 27 HILLIER ST SHEUNG WAN, HK
<b>Test specification:</b>	
<b>Standard</b> .....	IEC 62109-2:2011
<b>Test procedure</b> .....	Test report
<b>Non-standard test method</b> .....	N/A
<b>Test Report Form No.</b> .....	IEC62109_2B
<b>Test Report Form(s) Originator</b> .....	LCIE - Laboratoire Central des Industries Electriques
<b>Master TRF</b> .....	Dated 2016-11
<b>Copyright © 2016 IEC System of Conformity Assessment Schemes for Electrotechnical Equipment and Components (IECEE System). All rights reserved.</b>	
<p>This publication may be reproduced in whole or in part for non-commercial purposes as long as the IECEE is acknowledged as copyright owner and source of the material. IECEE takes no responsibility for and will not assume liability for damages resulting from the reader's interpretation of the reproduced material due to its placement and context.</p>	
<p>If this Test Report Form is used by non-IECEE members, the IECEE/IEC logo and the reference to the CB Scheme procedure shall be removed.</p>	
<p><b>This report is not valid as a CB Test Report unless signed by an approved CB Testing Laboratory and appended to a CB Test Certificate issued by an NCB in accordance with IECEE 02.</b></p>	











Test item description .....	PV Grid inverter	
Trade Mark .....	<b>EVVO</b>	
Manufacturer.....	Same as the applicant	
Model/Type reference.....	EVVO 1100TL-AV, EVVO 1600TL-AV, EVVO 2200TL-AV, EVVO 2700TL-AV, EVVO 3000TL-AV, EVVO 3200TL-AV	
Ratings .....	See copy of marking label and model list.	
<b>Responsible Testing Laboratory (as applicable), testing procedure and testing location(s):</b>		
<input checked="" type="checkbox"/> Testing Laboratory:	Shenzhen BALUN Technology Co., Ltd.	
Testing location/ address .....	Block B, 1st FL, Baisha Science and Technology Park, Shahe Xi Road, Nanshan District, Shenzhen, Guangdong Province, P.R. China	
Tested by (name, function, signature) .....	Ruoxi Li	
Approved by (name, function, signature) ..	Simon Qi	
<input type="checkbox"/> Testing procedure: CTF Stage 1:		
Testing location/ address .....		
Tested by (name, function, signature) .....		
Approved by (name, function, signature) ..		
<input type="checkbox"/> Testing procedure: CTF Stage 2:		
Testing location/ address .....		
Tested by (name + signature).....		
Witnessed by (name, function, signature) . :		
Approved by (name, function, signature) .. :		
<input type="checkbox"/> Testing procedure: CTF Stage 3:		
<input type="checkbox"/> Testing procedure: CTF Stage 4:		
Testing location/ address .....		
Tested by (name, function, signature) .....		
Witnessed by (name, function, signature) . :		
Approved by (name, function, signature) .. :		
Supervised by (name, function, signature) :		

<b>List of Attachments (including a total number of pages in each attachment):</b> See report BL-SZ19B0347-B01.	
<b>Summary of testing:</b>	
<b>Tests performed (name of test and test clause):</b> 4.4.4.15.1 Fault-tolerance of residual current monitoring 4.4.4.15.2 Fault-tolerance of automatic disconnecting means 4.4.4.17 Cooling system failure – Blanketing test 4.8.2 Array insulation resistance detection for inverters for ungrounded and functionally grounded arrays 4.8.3 Array residual current detection 4.8.3.5 Protection by residual current monitoring  Remark: - Other testing conditions considered in this test report, see General product information of the report BL-SZ19B0347-B01 for details.	<b>Testing location:</b>  See report BL-SZ19B0347-B01.
<b>Summary of compliance with National Differences (List of countries addressed):</b> List of countries addressed: See report See report BL-SZ19B0347-B01.	

**Copy of marking plate:**

The artwork below may be only a draft. The use of certification marks on a product must be authorized by the respective NCBs that own these marks.

<b>EVVO</b>	Solar Grid-tied Inverter
Model No:	EVVO 3200TL - AV
Max.DC Input Voltage	550V
Operating MPPT Voltage Range	50~550V
Max. Input Current	12A
Max. PV Isc	15A
Nominal Grid Voltage	L/N/PE, 230Vac
Max. Output Current	16A
Nominal Grid Frequency	50/60Hz
Max. Output Power	3300VA
Power Factor	1 (adjustable+/-0.8)
Ingress Protection	IP65
Operating Temperature Range	-30°C~+60°C
Protective Class	Class I
Inverter Topology	Non-Isolated
Factory - Shenzhen China	
Manufacturer : EVOLVE ENERGY GROUP CO., LIMITED	
Address :RM 702, 7/F FU FAI COMM CTR 27 HILLIER ST	
SHEUNG WAN, HK	
Global Head Quarters	
371 Sidco Industrial Estate	
Chennai 600098 India	
VDE0126-1-1,VDE-AR-N4105, IEC61727,	
IEC62116, UTE C15-712-1, AS4777	
       	

**Note:**

1. The above markings are the minimum requirements required by the safety standard. For the final production samples, the additional markings which do not give rise to misunderstanding may be added.
2. Label is attached on the side surface of enclosure and visible after installation Labels of other models are as the same with EVVO 3200TL-AV's except the parameters of rating.



<b>Test item particulars</b> .....	
<b>Equipment mobility</b> .....	<input type="checkbox"/> movable <input type="checkbox"/> hand-held <input type="checkbox"/> stationary <input checked="" type="checkbox"/> fixed <input type="checkbox"/> transportable <input type="checkbox"/> for building-in
<b>Connection to the mains</b> .....	<input type="checkbox"/> pluggable equipment <input type="checkbox"/> direct plug-in <input checked="" type="checkbox"/> permanent connection <input type="checkbox"/> for building-in
<b>Environmental category</b> .....	<input checked="" type="checkbox"/> outdoor <input type="checkbox"/> indoor unconditional <input type="checkbox"/> indoor conditional
<b>Over voltage category Mains</b> .....	<input type="checkbox"/> OVC I <input type="checkbox"/> OVC II <input checked="" type="checkbox"/> OVC III <input type="checkbox"/> OVC IV
<b>Over voltage category PV</b> .....	<input type="checkbox"/> OVC I <input checked="" type="checkbox"/> OVC II <input type="checkbox"/> OVC III <input type="checkbox"/> OVC IV
<b>Mains supply tolerance (%)</b> .....	According to specified supply range
<b>Tested for power systems</b> .....	TN
<b>IT testing, phase-phase voltage (V)</b> .....	N/A
<b>Class of equipment</b> .....	<input checked="" type="checkbox"/> Class I <input type="checkbox"/> Class II <input type="checkbox"/> Class III <input type="checkbox"/> Not classified
<b>Mass of equipment (kg)</b> .....	See model list
<b>Pollution degree</b> .....	PD3(Inside PD2)
<b>IP protection class</b> .....	IP65
.....	
<b>Possible test case verdicts:</b>	
- test case does not apply to the test object .....	N/A
- test object does meet the requirement .....	P (Pass)
- test object does not meet the requirement .....	F (Fail)
<b>Testing</b> .....	
<b>Date of receipt of test item</b> .....	See report BL-SZ19B0347-B01
<b>Date (s) of performance of tests</b> .....	See report BL-SZ19B0347-B01
<b>General remarks:</b>	
"(See Enclosure #)" refers to additional information appended to the report. "(See appended table)" refers to a table appended to the report. The tests results presented in this report relate only to the object tested. This report shall not be reproduced except in full without the written approval of the testing laboratory. List of test equipment must be kept on file and available for review. Additional test data and/or information provided in the attachments to this report. <b>Throughout this report a <input type="checkbox"/> comma / <input checked="" type="checkbox"/> point is used as the decimal separator.</b>	
<b>Manufacturer's Declaration per sub-clause 4.2.5 of IEC62 02:</b>	
The application for obtaining a CB Test Certificate includes more than one factory location and a declaration from the Manufacturer stating that the sample(s) submitted for evaluation is (are) representative of the products from each factory has been provided .....	<input type="checkbox"/> Yes <input checked="" type="checkbox"/> Not applicable

**When differences exist; they shall be identified in the General product information section.**

**Name and address of factory (ies).....:**

See report BL-SZ19B0347-B01

**General product information:**

See report BL-SZ19B0347-B01

Throughout the test report following abbreviations may be used:

●	cl	clearance	●	int	internal distance
●	dcr	creepage distance	●	o-c	open-circuit
●	dti	distance through insulation	●	o-l	overload
●	PCE	Power Conversion Equipment	●	s-c	short-circuit
●	BI	basic insulation	●	SI	supplementary insulation
●	DI	double insulation	●	RI	reinforced insulation



IEC 62109-2			
Clause	Requirement + Test	Result - Remark	Verdict
<b>4</b>	<b>GENERAL TESTING REQUIREMENTS</b>		P
<b>4.4.4</b>	<b>Single fault conditions to be applied</b>		P
<b>4.4.4.15</b>	<b>Fault-tolerance of protection for grid-interactive inverters</b>		P
<b>4.4.4.15.1</b>	<b>Fault-tolerance of residual current monitoring according to 4.8.3.5: the residual current monitoring system operates properly</b>	See appended table 4.4.4.15.1	P
	a)..- The inverter ceases to operate		P
	- Indicates a fault in accordance with §13.9		P
	- Disconnect from the mains		P
	- not re-connect after any sequence of removing and reconnecting PV power		P
	- not re-connect after any sequence of removing and reconnecting AC power		P
	- not re-connect after any sequence of removing and reconnecting both PV and AC power		P
	b)..- The inverter continues to operate		P
	- the residual current monitoring system operates properly under single fault condition		P
	- Indicates a fault in accordance with §13.9		P
	c)..- The inverter continues to operate regardless of loss of residual current monitoring functionality		P
	- not re-connect after any sequence of removing and reconnecting PV power		P
	- not re-connect after any sequence of removing and reconnecting AC power		P
	- not re-connect after any sequence of removing and reconnecting both PV and AC power		P
	- Indicates a fault in accordance with §13.9		P
<b>4.4.4.15.2</b>	<b>Fault-tolerance of automatic disconnecting means</b>		P
<b>4.4.4.15.2.1</b>	<b>The means provided for automatic disconnection of a grid-interactive inverter from the mains shall:</b>		P
	- disconnect all grounded current-carrying conductors from the mains		P
	- disconnect all ungrounded current-carrying conductors from the mains		P
	- be such that with a single fault applied to the disconnection means or to any other location in the inverter, at least basic insulation or simple separation is maintained between the PV array and the mains when the disconnecting means is intended to be in the open state.	See appended table 4.4.4.15.2 Fault-tolerance of automatic disconnecting	P
<b>4.4.4.15.2.2</b>	<b>Design of insulation or separation complies with requirements of 7.3.7 of Part 1: report here Part 1 comment and verdict.</b>		P
<b>4.4.4.15.2.3</b>	<b>For non-isolated inverter, automatic checking of the isolation provided by a disconnect means after single fault.</b>	See appended test table 4.4.4.15.2 Fault-tolerance of automatic disconnecting.	P
	If the check fail:		P
	- any still-functional disconnection means shall be left in the open position		P

IEC 62109-2			
Clause	Requirement + Test	Result - Remark	Verdict
	- at least basic or simple separation shall be maintained between the PV input and the mains		P
	- the inverter shall not start operation		P
	- the inverter shall indicate a fault in accordance with 13.9		P
<b>4.4.4.16</b>	<b>A stand-alone inverter with a transfer switch to transfer AC loads from the mains or other AC bypass source to the inverter output:</b>	Grid-connected PV Inverter.	N/A
	- shall continue to operate normally		N/A
	- shall not present a risk of fire as the result of an out-of-phase transfer		N/A
	- shall not present a risk of shock as the result of an out-of-phase transfer		N/A
	- And having control preventing switching: components for malfunctioning .....		N/A
<b>4.4.4.17</b>	<b>Cooling system failure – Blanketing test No hazards according to the criteria of sub-clause 4.4.3 of Part 1 shall result from blanketing the inverter This test is not required for inverters restricted to use only in closed electrical operating areas.</b>	See appended test table Cooling system failure – Blanketing test.	P
	Test stop condition: time duration value or stabilized temperature .....		P
<b>4.7</b>	<b>ELECTRICAL RATINGS TESTS</b>		P
<b>4.7.4</b>	<b>Stand-alone Inverter AC output voltage and frequency</b>		N/A
<b>4.7.4.1</b>	<b>General</b>		N/A
<b>4.7.4.2</b>	<b>Steady state output voltage at nominal DC input The steady-state AC output voltage shall not be less than 90 % or more than 110 % of the rated nominal voltage with the inverter supplied with its nominal value of DC input voltage.</b>	See appended test table 4.7.4 Steady state Inverter AC output voltage and frequency	N/A
<b>4.7.4.3</b>	<b>Steady state output voltage across the DC input range The steady-state AC output voltage shall not be less than 85 % or more than 110 % of the rated nominal voltage with the inverter supplied with any value within the rated range of DC input voltage.</b>	See appended test table 4.7.4 Steady state Inverter AC output voltage and frequency	N/A
<b>4.7.4.4</b>	<b>Load step response of the output voltage at nominal DC input The AC output voltage shall not be less than 85 % or more than 110 % of the rated nominal voltage for more than 1,5 s after application or removal of a resistive load.</b>	See appended test table 4.7.4 Steady state Inverter AC output voltage and frequency	N/A
<b>4.7.4.5</b>	<b>Steady state output frequency The steady-state AC output frequency shall not vary from the nominal value by more than +4 % or –6 %.</b>	See appended test table 4.7.4 Steady state Inverter AC output voltage and frequency	N/A
<b>4.7.5</b>	<b>Stand-alone inverter output voltage waveform</b>		N/A
<b>4.7.5.1</b>	<b>General</b>		N/A
<b>4.7.5.2</b>	<b>The AC output voltage waveform of a sinusoidal output stand-alone inverter shall have a total harmonic distortion (THD) not exceeding of 10 % and no individual harmonic at a level exceeding 6 %.</b>		N/A
<b>4.7.5.3</b>	<b>Non-sinusoidal output waveform requirements</b>		N/A

IEC 62109-2			
Clause	Requirement + Test	Result - Remark	Verdict
4.7.5.3.1	<b>General</b>		N/A
4.7.5.3.2	<b>The total harmonic distortion (THD) of the voltage waveform shall not exceed 40 %.</b>		N/A
4.7.5.3.3	<b>The slope of the rising and falling edges of the positive and negative half-cycles of the voltage waveform shall not exceed 10 V/μs measured between the points at which the waveform has a voltage of 10 % and 90 % of the peak voltage for that half-cycle.</b>		N/A
4.7.5.3.4	<b>The absolute value of the peak voltage of the positive and negative half-cycles of the waveform shall not exceed 1,414 times 110 % of the RMS value of the rated nominal AC output voltage.</b>		N/A
4.7.5.4	<b>Information requirements for non-sinusoidal waveforms</b> <b>The instructions provided with a stand-alone inverter not complying with 4.7.5.2 shall include the information in 5.3.2.6.</b>		N/A
4.7.5.5	<b>Output voltage waveform requirements for inverters for dedicated loads.</b> <b>For an inverter that is intended only for use with a known dedicated load, the following requirements may be used as an alternative to the waveform requirements in 4.7.5.2 to 4.7.5.3.</b>		N/A
	The combination of the inverter and dedicated load shall be evaluated to ensure that the output waveform does not cause any hazards in the load equipment and inverter, or cause the load equipment to fail to comply with the applicable product safety standards.	See attached document: 4.7.5.5 Evaluation of inverter for dedicated load	N/A
	The inverter shall be marked with symbols 9 and 15 of Table C.1 of Part 1.		N/A
	The installation instructions provided with the inverter shall include the information in 5.3.2.13.		N/A
<b>4.8</b>	<b>ADDITIONAL TESTS FOR GRID-INTERACTIVE INVERTERS</b>		P
4.8.1	<b>General requirements regarding inverter isolation and array grounding</b>		N/A
	- Type of Array grounding supported .....		N/A
	- Inverter isolation .....		N/A
4.8.2	<b>Array insulation resistance detection for inverters for ungrounded and functionally grounded arrays</b>	(See attached table)	P
4.8.2.1	<b>Array insulation resistance detection for inverters for ungrounded arrays</b>	See below.	P
	Inverter shall have means to measure DC insulation resistance from PV input (array) to ground before starting operation		P
	Or Inverter shall be provided with instruction in accordance with 5.3.2.11.		P
	Measured DC insulation resistance: .....		P
	Inverter measurement circuit shall be capable of detecting insulation resistance below the limit value $R = V_{max}/30mA$ under normal conditions		P
	Inverter measurement circuit shall be capable of detecting insulation resistance below the limit value $R = V_{max}/30mA$ with ground fault in the PV array		P
	Isolated inverters shall indicate a fault if the insulation		P

IEC 62109-2			
Clause	Requirement + Test	Result - Remark	Verdict
	resistance is less than the limit value		
	Isolated inverter fault indication maintained until insulation resistance has recovered to a value higher than the limit value	Non-isolated inverter	N/A
	Non-isolated inverters, or inverters with isolation not complying with the leakage current limits in the minimum inverter isolation requirements in Table 30:		P
	- shall indicate a fault in accordance with 13.9		P
	- shall not connect to the mains		P
<b>4.8.2.2</b>	<b>Array insulation resistance detection for inverters for functionally grounded arrays</b>	Inverters connected to ungrounded arrays.	N/A
	a-1)The value of the total resistance, including the intentional resistance for array functional grounding, the expected insulation resistance of the array to ground, and the resistance of any other networks connected to ground (for example measurement networks) must not be lower than $R = (V_{MAX} PV/30 \text{ mA})$ ohms.		N/A
	a-2) The installation instructions shall include the information required in 5.3.2.12.		N/A
	b-1) As an alternative to a), or if a resistor value lower than in a) is used, the inverter shall incorporate means to detect, during operation, if the total current through the resistor and any networks (for example measurement networks) in parallel with it, exceeds the residual current values and times in Table 31		N/A
	b-2) Inverter shall either disconnect the resistor or limit the current by other means .....		N/A
	b-3) If the inverter is a non-isolated inverter, or has isolation not complying with the leakage current limits in the minimum inverter isolation requirements in Table 30, it shall also disconnect from the mains.		N/A
	c) The inverter shall have means to measure the DC insulation resistance from the PV input to ground before starting operation, in accordance with 4.8.2.1.		N/A
<b>4.8.3</b>	<b>Array residual current detection</b>		P
<b>4.8.3.1</b>	<b>General</b>		P
<b>4.8.3.2</b>	<b>30 mA touch current type test for isolated inverters</b>	See appended table 4.8.3.2 30mA touch current type test for isolated inverters	P
<b>4.8.3.3</b>	<b>Fire hazard residual current type test for isolated inverters</b>	See appended table 4.8.3.3 Fire hazard residual current type test for isolated inverters	P
<b>4.8.3.4</b>	<b>Protection by application of RCD's</b>	Not used.	N/A
	- The requirement for additional protection in 4.8.3.1 can be met by provision of an RCD with a residual current setting of 30 mA, located between the inverter and the mains..		N/A
	- The selection of the RCD type to ensure compatibility with the inverter must be made according to rules for RCD selection in Part 1.		N/A
	- The RCD provided integral to the inverter, or		N/A
	- The RDC provided by the installer if details of the rating, type, and location for the RCD are given in the		N/A

IEC 62109-2			
Clause	Requirement + Test	Result - Remark	Verdict
	installation instructions per 5.3.2.9.		
<b>4.8.3.5</b>	<b>Protection by residual current monitoring</b>	RCMU used for monitoring the residual current.	P
<b>4.8.3.5.1</b>	<b>General</b>		P
	Where required by Table 30, the inverter shall provide residual current monitoring that functions whenever the inverter is connected to the mains with the automatic disconnection means closed.		P
	The residual current monitoring means shall measure the total (both a.c. and d.c. components) RMS current.		P
	As indicated in Table 30 for different inverter types, array types, and inverter isolation levels, detection may be required for excessive continuous residual current, excessive sudden changes in residual current, or both, according to the following limits:		P
	a) Continuous residual current: The inverter shall disconnect within 0,3 s and indicate a fault in accordance with 13.9 if the continuous residual current exceeds:		P
	- maximum 300 mA for inverters with continuous output power rating $\leq 30$ kVA;	3.3K	P
	- maximum 10 mA per kVA of rated continuous output power for inverters with continuous output power rating > 30 kVA.		N/A
	The inverter may attempt to re-connect if the array insulation resistance meets the limit in 4.8.2.		P
	b) Sudden changes in residual current: The inverter shall disconnect from the mains within the time specified in Table 31		P
	The inverter indicates a fault in accordance with 13.9, if a sudden increase in the RMS residual current is detected exceeding the value in the table.		P
	The inverter may attempt to re-connect if the array insulation resistance meets the limit in 4.8.2.		P
<b>4.8.3.5.2</b>	<b>Test for detection of excessive continuous residual current: test repeated 5 times and time to disconnect shall not exceed 0,3 s.</b>	See appended test table 4.8.3.5.2 Test for detection of excessive continuous residual current	P
<b>4.8.3.5.3</b>	<b>Test for detection of sudden changes in residual current repeated 5 times and each of the 5 results shall not exceed the time limit indicated in for each row (30mA, 60mA and 150mA) of Table 31.</b>		P
<b>4.8.3.6</b>	<b>Systems located in closed electrical operating areas</b>	Not specified to be located in closed electrical operating area.	N/A
	<b>The protection against shock hazard is not required if the installation information provided with the inverter indicates the restriction for use in a closed electrical operating area, and</b>		N/A
	Installation information indicates what forms of shock hazard protection are and are not provided integral to the inverter, in accordance with 5.3.2.7.		N/A
	The inverter shall be marked as in 5.2.2.6.		N/A
<b>5</b>	<b>MARKING AND DOCUMENTATION</b>		P
<b>5.1</b>	<b>Marking</b>		P

IEC 62109-2			
Clause	Requirement + Test	Result - Remark	Verdict
<b>5.1.4</b>	<b>Equipment ratings</b>		P
	PV input ratings:		P
	- Vmax PV (absolute maximum) (d.c. V)		P
	- Isc PV (absolute maximum) (d.c. A)		P
	a.c. output ratings:		P
	- Voltage (nominal or range) (a.c. V)		P
	- Current (maximum continuous) (a.c. A)		P
	- Frequency (nominal or range) (Hz)		P
	- Power (maximum continuous) (W or VA)		P
	- Power factor range		P
	a.c input ratings:		N/A
	- Voltage (nominal or range) (a.c. V)		N/A
	- Current (maximum continuous) (a.c. A)		N/A
	- Frequency (nominal or range) (Hz)		N/A
	d.c. output ratings:		N/A
	- Voltage (nominal or range) (d.c. V)		N/A
	- Current (maximum continuous) (d.c. A)		N/A
	Protective class (I or II or III)		P
	Ingress protection (IP) rating per part 1		P
	An inverter that is adjustable for more than one nominal output voltage shall be marked to indicate the particular voltage for which it is set when shipped from the factory.		N/A
<b>5.2</b>	<b>Warning markings</b>		P
<b>5.2.2</b>	<b>Content for warning markings</b>		P
<b>5.2.2.6</b>	<b>Inverters for closed electrical operating areas</b>		P
	Where required by 4.8.3.6, an inverter not provided with full protection against shock hazard on the PV array shall be marked with a warning that the inverter is only for use in a closed electrical operating area, and referring to the installation instructions.		P
<b>5.3</b>	<b>Documentation</b>		P
<b>5.3.2</b>	<b>Information related to installation</b>		P
<b>5.3.2.1</b>	<b>Ratings. Subclause 5.3.2 of Part 1 requires the documentation to include ratings information for each input and output. For inverters this information shall be as in Table 33 below. Only those ratings that are applicable based on the type of inverter are required.</b>		P
	PV input quantities :		P
	- Vmax PV (absolute maximum) (d.c. V)		P
	- PV input operating voltage range (d.c. V)		P
	- Maximum operating PV input current (d.c. A)		P
	- Isc PV (absolute maximum) (d.c. A)		P
	- Isc PV (absolute maximum) (d.c. A)		P
	- Max. inverter backfeed current to the array (a.c. or d.c. A)		P
	a.c. output quantities:		P
	- Voltage (nominal or range) (a.c. V)		P
	- Current (maximum continuous) (a.c. A)		P
	- Current (inrush) (a.c. A, peak and duration)		P
	- Frequency (nominal or range) (Hz)		P
	- Power (maximum continuous) (W or VA)		P
	- Power factor range		P

IEC 62109-2			
Clause	Requirement + Test	Result - Remark	Verdict
	- Maximum output fault current (a.c. A, peak and duration or RMS)		P
	- Maximum output overcurrent protection (a.c. A)		P
	a.c. input quantities:		N/A
	- Voltage (nominal or range) (a.c. V)		N/A
	- Current (maximum continuous) (a.c. A)		N/A
	- Current (inrush) (a.c. A, peak and duration)		N/A
	- Frequency (nominal or range) (Hz)		N/A
	d.c input (other than PV) quantities:		N/A
	- Voltage (nominal or range) (d.c. V)		N/A
	- Nominal battery voltage (d.c. V)		N/A
	- Current (maximum continuous) (d.c. A)		N/A
	d.c. output quantities:		N/A
	- Voltage (nominal or range) (d.c. V)		N/A
	- Nominal battery voltage (d.c. V)		N/A
	- Current (maximum continuous) (d.c. A)		N/A
	Protective class (I or II or III)		P
	Ingress protection (IP) rating per part 1		P
<b>5.3.2.2</b>	<b>Grid-interactive inverter setpoints</b>		P
	For a grid-interactive unit with field adjustable trip points, trip times, or reconnect times, the presence of such controls, the means for adjustment, the factory default values, and the limits of the ranges of adjustability shall be provided in the documentation for the PCE or in other format such as on a website. Provided solution: .....		P
	The setting of field adjustable setpoints shall be accessible from the PCE		P
<b>5.3.2.3</b>	<b>Transformers and isolation</b>		N/A
	whether an internal isolation transformer is provided, and if so, what level of insulation (functional, basic, reinforced, or double) is provided by that transformer. The instructions shall also indicate what the resulting installation requirements are regarding such things as earthing or not earthing the array, providing external residual current detection devices, etc.		N/A
	An inverter shall be provided with information to the installer regarding:		-
	- providing of internal isolation transformer		N/A
	- the level of insulation (functional, basic, reinforced, or double)		N/A
	The instructions shall also indicate what the resulting installation requirements are regarding:		-
	- earthing or not earthing the array		N/A
	- providing external residual current detection devices		N/A
	- requiring an external isolation transformer,		N/A
<b>5.3.2.4</b>	<b>Transformers required but not provided</b>		N/A
	An inverter that requires an external isolation transformer not provided with the unit, shall be provided with instructions that specify, and for the external isolation transformer with which it is intended to be used:		N/A
	- the configuration type		N/A
	- electrical ratings		N/A
	- environmental ratings		N/A

IEC 62109-2			
Clause	Requirement + Test	Result - Remark	Verdict
<b>5.3.2.5</b>	<b>PV modules for non-isolated inverters</b>		P
	Non-isolated inverters shall be provided with installation instructions that require PV modules that have an IEC 61730 Class A rating		P
	If the maximum AC mains operating voltage is higher than the PV array maximum system voltage then the instructions shall require PV modules that have a maximum system voltage rating based upon the AC mains voltage.		N/A
<b>5.3.2.6</b>	<b>Non-sinusoidal output waveform information</b>	Grid-connection inverter.	N/A
	The instruction manual for a stand-alone inverter not complying with 4.7.5.2 shall include a warning that:		N/A
	- the waveform is not sinusoidal,		N/A
	- some loads may experience increased heating,		N/A
	- the user should consult the manufacturers of the intended load equipment before operating that load with the inverter		N/A
	The inverter manufacturer shall provide information regarding:		-
	- what types of loads may experience increased heating		N/A
	- recommendations for maximum operating times with such loads		N/A
	The inverter manufacturer shall specify for the waveforms as determined by the testing in 4.7.5.3.2 through 4.7.5.3.4.:		-
	- THD		N/A
	- slope		N/A
	- peak voltage		N/A
<b>5.3.2.7</b>	<b>Systems located in closed electrical operating areas</b>	Not specified to be located in closed electrical operating area.	N/A
	Where required by 4.8.3.6, an inverter not provided with full protection against shock hazard on the PV array shall be provided with installation instructions:		N/A
	- requiring that the inverter and the array must be installed in closed electrical operating areas		N/A
	- indicating which forms of shock hazard protection are and are not provided integral to the inverter (for example the RCD, isolation transformer complying with the 30 mA touch current limit, or residual current monitoring for sudden changes)		N/A
<b>5.3.2.8</b>	<b>Stand-alone inverter output circuit bonding</b>	Grid-connection inverter.	N/A
	Where required by 7.3.10, the documentation for an inverter shall include the following:		N/A
	- if output circuit bonding is required but is not provided integral to the inverter, the required means shall be described in the installation instructions, including which conductor is to be bonded and the required current carrying capability or cross-section of the bonding means;		N/A
	- if the output circuit is intended to be floating, the documentation for the inverter shall indicate that the output is floating.		N/A
<b>5.3.2.9</b>	<b>Protection by application of RCD's</b>	Integrated RCM provided in inverter.	N/A



IEC 62109-2			
Clause	Requirement + Test	Result - Remark	Verdict
	Where the requirement for additional protection in 4.8.3.1 is met by requiring an RCD that is not provided integral to the inverter, as allowed by 4.8.3.4, the installation instructions shall state the need for the RCD,.		N/A
	and shall specify its rating, type, and required circuit location		N/A
<b>5.3.2.10</b>	<b>Remote indication of faults</b>		P
	The installation instructions shall include an explanation of how to properly make connections to (where applicable), and use, the electrical or electronic fault indication required by 13.9.		P
<b>5.3.2.11</b>	<b>External array insulation resistance measurement and response</b>		N/A
	The installation instructions for an inverter for use with ungrounded arrays that does not incorporate all the aspects of the insulation resistance measurement and response requirements in 4.8.2.1, must include:		N/A
	- for isolated inverters: an explanation of what aspects of array insulation resistance measurement and response are not provided, and		N/A
	- an instruction to consult local regulations to determine if any additional functions are required or not;		N/A
	- for non-isolated inverters: an explanation of what external equipment must be provided in the system, and		N/A
	- what the setpoints and response implemented by that equipment must be, and:		N/A
	- how that equipment is to be interfaced with the rest of the system.		N/A
<b>5.3.2.12</b>	<b>Array functional grounding information</b>		N/A
	Where approach a) of 4.8.2.2 is used, the installation instructions for the inverter shall include all of the following:		N/A
	a) the value of the total resistance between the PV circuit and ground integral to the inverter .....		N/A
	b) the minimum array insulation resistance to ground that system designer or installer must meet when selecting the PV panel and system design, based on the minimum value that the design of the PV functional grounding in the inverter was based on .....		N/A
	c) the minimum value of the total resistance $R = V_{MAX} PV/30 \text{ mA}$ that the system must meet, with an explanation of how to calculate the total .....		N/A
	d) a warning that there is a risk of shock hazard if the total minimum resistance requirement is not met.		N/A
<b>5.3.2.13</b>	<b>Stand-alone inverters for dedicated loads</b>	Grid-connection inverter.	N/A
	Where the approach of 4.7.5.5 is used, the installation instructions for the inverter shall include a warning that the inverter is only to be used with the dedicated load for which it was evaluated, and		N/A
	shall specify the dedicated load.		N/A
<b>5.3.2.14</b>	<b>Identification of firmware version(s)</b>	See report BL-SZ19B0347-B01.	P

IEC 62109-2			
Clause	Requirement + Test	Result - Remark	Verdict
	An inverter utilizing firmware for any protective functions shall provide means to identify the firmware version.		P
	This can be a marking, but the information can also be provided by a display panel, communications port or any other type of user interface.....		P
<b>7</b>	<b>PROTECTION AGAINST ELECTRIC SHOCK AND ENERGY HAZARDS</b>		P
<b>7.3</b>	<b>Protection against electric shock</b>		P
<b>7.3.10</b>	<b>Additional requirements for stand-alone inverters</b>		N/A
	One circuit conductor bonded to earth to create a grounded conductor and an earthed system.		N/A
	The means used to bond the grounded conductor to protective earth provided within the inverter or as part of the installation		N/A
	If not provided integral to the inverter, the required means shall be described in the installation instructions as per 5.3.2.8.		N/A
	The means used to bond the grounded conductor to protective earth shall comply with the requirements for protective bonding in Part 1,		N/A
	If the bond can only ever carry fault currents in stand-alone mode, the maximum current for the bond is determined by the inverter maximum output fault current.		N/A
	Output circuit bonding arrangements shall ensure that in any mode of operation, the system only has the grounded circuit conductor bonded to earth in one place at a time..		N/A
	Switching arrangements may be used, in which case the switching device used is to be subjected to the bond impedance test along with the rest of the bonding path		N/A
	Inverters intended to have a circuit conductor bonded to earth shall not impose any normal current on the bond except for leakage current.		N/A
	Outputs that are intentionally floating with no circuit conductor bonded to ground, must not have any voltages with respect to ground that are a shock hazard in accordance with Clause 7 of Parts 1 and 2.		N/A
	The documentation for the inverter shall indicate that the output is floating as per 5.3.2.8.		N/A
<b>7.3.11</b>	<b>Functionally grounded arrays</b>		N/A
	All PV conductors in a functionally grounded array shall be treated as being live parts with respect to protection against electric shock.		N/A
<b>9</b>	<b>PROTECTION AGAINST FIRE HAZARDS</b>		P
<b>9.3</b>	<b>Short-circuit and overcurrent protection</b>		P
<b>9.3.4</b>	<b>Inverter backfeed current onto the array</b>		P
	The backfeed current testing and documentation requirements in Part 1 apply, including but not limited to the following.		P
	Inverter backfeed current onto the PV array maximum value.....		P
	This inverter backfeed current value shall be provided in the installation instructions regardless of the value of the current, in accordance with Table 33.		P
<b>13</b>	<b>PHYSICAL REQUIREMENTS</b>		P
<b>13.9</b>	<b>Fault indication</b>		P

IEC 62109-2			
Clause	Requirement + Test	Result - Remark	Verdict
	Where this Part 2 requires the inverter to indicate a fault, both of the following shall be provided:		P
	a) a visible or audible indication, integral to the inverter, and detectable from outside the inverter, and	LCD panel is available for fault indication.	P
	b) an electrical or electronic indication that can be remotely accessed and used.	RS485 port are available for remoting communication	P
	The installation instructions shall include information regarding how to properly make connections (where applicable) and use the electrical or electronic means in b) above, in accordance with 5.3.2.10.		P

IEC 62109-2			
Clause	Requirement + Test	Result - Remark	Verdict

<b>4.4.4</b>	<b>TABLE: Single fault condition to be applied</b>			<b>P</b>
	<b>Ambient temperature (°C)</b> .....	25°C, if not stated otherwise		—
	<b>Power source for EUT: Manufacturer, model/type, output rating</b> .....	DC Source: Chroma, 62150H-1000S, 15kW.  AC Source: Kewell, KACM-75-33, 75KVA.		—

<b>4.4.4.15.1 Fault-tolerance of residual current monitoring</b>						
Component No.	Fault	Supply voltage (V)	Test time	Fuse #	Fuse current (A)	Observation
Residual Current monitoring unit	Loss / failure (RC62 S-C)	DC 500	10 min.	--	--	PCE didn't start to work. Relay opened. SD, DG, RO, NCD, NH, PEST.
Residual Current monitoring unit	Loss / failure (CC76 S-C)	DC 500	10 min.	--	--	PCE didn't start to work. Relay opened. SD, DG, RO, NCD, NH, PEST.
<b>Check that the residual current monitoring operates properly</b>						RCMU operates properly.

<b>Legend</b>			
FID	Fault Indication	MT	Max. Temperature
SD	PCE Shut Down:	DG	Disconnection To Grid
RO	Recovered to Operate after removing the single fault setting	NCD	No Comp. or parts Damaged
NH	No Hazards occurred	PEST	Pass the Electric Strength Test.
BI	Basic insulation	SI	Supplementary insulation
DI	Double insulation	RI	Reinforced insulation
FI	Functional insulation	o-l	over-load.
s-c	short-circuited	o-c	open-circuited

**Supplementary information:**  
 The electric strength test performed after fault condition test and see appended table 7.5.2 of Part1 for detailed test conditions.

IEC 62109-2			
Clause	Requirement + Test	Result - Remark	Verdict

<b>4.4.4</b>	<b>TABLE: Single fault condition to be applied</b>		<b>P</b>
	<b>Ambient temperature (°C)</b> .....	25°C, if not stated otherwise	—
	<b>Power source for EUT: Manufacturer, model/type, output rating</b> .....	DC Source: Chroma, 62150H-1000S, 15kW.  AC Source: Kewell, KACM-75-33, 75KVA.	—

**4.4.4.15.2 Fault-tolerance of automatic disconnecting means**

Component No.	Fault	Supply voltage (V)	Test time	Fuse #	Fuse current (A)	Observation
RYP3 Pin3-4	S-C	PV: 500Vdc AC output: 230Vac	5min	--	--	PCE didn't start to work. Relay opened. SD, DG, RO, NCD, NH, PEST.
RYP2 Pin3-4	S-C	PV: 500Vdc AC output: 230Vac	5min	--	--	PCE didn't start to work. Relay opened. SD, DG, RO, NCD, NH, PEST.
RYP4 Pin3-4	S-C	PV: 500Vdc AC output: 230Vac	5min	--	--	PCE didn't start to work. Relay opened. SD, DG, RO, NCD, NH, PEST.
RYP5 Pin3-4	S-C	PV: 500Vdc AC output: 230Vac	5min	--	--	PCE didn't start to work. Relay opened. SD, DG, RO, NCD, NH, PEST.

<b>Check that the relays fulfil the basic insulation or simple separation based on the PV circuit working voltage.</b>	Relays fulfil the basic insulation or simple separation.
--	--

<b>Each active phase can be switched. (L and N)</b>	All pole disconnection.
---	-------------------------

Legend

FID	Fault Indication	MT	Max. Temperature
SD	PCE Shut Down:	DG	Disconnection To Grid
RO	Recovered to Operate after removing the single fault setting	NCD	No Comp. or parts Damaged
NH	No Hazards occurred	PEST	Pass the Electric Strength Test.
BI	Basic insulation	SI	Supplementary insulation
DI	Double insulation	RI	Reinforced insulation
FI	Functional insulation	o-l	over-load.
s-c	short-circuited	o-c	open-circuited

**Supplementary information:**  
The electric strength test performed after fault condition test and see appended table 7.5.2 of Part1 for detailed test conditions.

IEC 62109-2			
Clause	Requirement + Test	Result - Remark	Verdict

<b>4.4.4.17</b>	<b>Cooling system failure – Blanketing test</b>		<b>P</b>
	Test voltage (Vdc).....:	300	—
	Test current (Idc)	11.2	—
	Test voltage (Vac).....:	231.1	—
	Test current (Iac)	14.2	—
	t <sub>amb1</sub> (°C) .....	See below.	—
	t <sub>amb2</sub> (°C) .....	See below.	—
<b>maximum temperature T of part/at::</b>		<b>T (°C)</b>	<b>T<sub>max</sub> (°C)</b>
	1. Ambient	25	-
	2. Enclosure outside near panel (non-metallic)	81.3	-
	3. Enclosure outside near inverter inductor (metallic)	86.7	-
	4. Mount surface	88.1	-

**Supplementary information:**

The inverter was operated at full power at 25°C.

The test was stopped when the over temperature protection device operated and no external surfaces of the inverter were at maximum temperature exceeding 90°C.

<b>4.7.4</b>	<b>TABLE: Steady state Inverter AC output voltage and frequency</b>		<b>N/A</b>
	Nominal DC input (V)		--
	Nominal output AC voltage (V) :		
<b>AC output U (V)</b>	<b>Frequency (Hz)</b>	<b>Condition/status</b>	<b>Comments</b>
--	--	<b>Without load</b>	--
--	--	<b>Resistive load application</b>	--
--	--	<b>Resistive load removal</b>	--

**Supplementary information:**

IEC 62109-2			
Clause	Requirement + Test	Result - Remark	Verdict

4.8.2	TABLE: Array insulation resistance detection for inverters for ungrounded and functionally grounded arrays			P
4.8.2.1	Array insulation resistance detection for inverters for ungrounded arrays			P
DC Voltage below minimum operating voltage (V)	DC Voltage for inverter begin operation (V)	Resistance between ground and PV input terminal ( $\Omega$ )	Required Insulation resistance $R = (V_{MAX PV} / 30mA)$ ( $\Omega$ )	Identification
<b>DC+</b>				
50	300	I.F.	1.0M $\Omega$	I.F.: Isolation Failure N.O.: Normal Operation
50	300	I.F.	1.0M $\Omega$	
50	300	I.F.	1.0M $\Omega$	
50	300	I.F.	1.0M $\Omega$	
50	300	N.O.	1.1M $\Omega$	
50	300	N.O.	1.1M $\Omega$	
<b>DC-</b>				
50	300	I.F.	1.0M $\Omega$	I.F.: Isolation Failure N.O.: Normal Operation
50	300	I.F.	1.0M $\Omega$	
50	300	I.F.	1.0M $\Omega$	
50	300	I.F.	1.0M $\Omega$	
50	300	N.O.	1.1M $\Omega$	
50	300	N.O.	1.1M $\Omega$	
<b>Note:</b>				
For isolated inverters, shall indicate a fault in accordance with 13.9 (operation is allowed); the fault indication shall be maintained until the array insulation resistance has recovered to a value higher than the limit above For non-isolated inverters, or inverters with isolation not complying with the leakage current limits in the minimum inverter isolation requirements in Table 30, shall indicate a fault in accordance with 13.9, and shall not connect to the mains; the inverter may continue to make the measurement, may stop indicating a fault and may connect to the mains if the array insulation resistance has recovered to a value higher than the limit above. It is not required to test all PV input terminals if analysis of the design indicates that one or more terminals can be expected to have the same result, for example where multiple PV string inputs are in parallel.				
<b>Supplementary information:</b>				
1) I.F. (FID: Isolation Failure)				
2) Array Insulation Resistance Threshold Value $R = 18.3 [k \Omega]$ (should be larger than $R = V_{MAX PV} / 30mA$ ) $\Omega$ .				
3) Setting isolation Failure Value 1.05M $\Omega$				

IEC 62109-2			
Clause	Requirement + Test	Result - Remark	Verdict

<b>4.8.3.2</b>	<b>TABLE: 30mA touch current type test for isolated inverters</b>		<b>N/A</b>
	<b>Condition</b>	<b>Current (mA)</b>	<b>Limit ( 30mA)</b>
	<b>DC+ to PE</b>	--	--
	<b>DC- to PE</b>	--	--
<b>Supplementary information:</b> Non-isolated type inverter.			

<b>4.8.3.3</b>	<b>TABLE: Fire hazard residual current type test for isolated inverters</b>		<b>N/A</b>
	<b>Condition</b>	<b>Current (mA)</b>	<b>Limit ( 300mA or 10mA per kVA)</b>
	<b>DC+ to PE</b>	--	--
	<b>DC- to PE</b>	--	--
<b>Supplementary information:</b> Non-isolated type inverter.			



IEC 62109-2			
Clause	Requirement + Test	Result - Remark	Verdict

4.8.3.5	TABLE: Protection by residual current monitoring		P
Test conditions:		Output power (kVA) : 500Vdc Input voltage ( $V_{DC}$ ): 3.3kW Frequency (Hz) 50Hz Output AC Voltage ( $V_{AC}$ ): 230Vac	
4.8.3.5.2	Test for detection of excessive continuous residual current		P
Fault Current (mA)		Disconnection time (ms)	
Measured Fault Current	Limit 300mA for output power $\leq$ 30 kVA 10mA per kVA for output power $>$ 30 kVA	Measured Disconnection time	Limit
<b>+ PV to N:</b>			
251.0	330	210.5	300
250.7	330	219.0	300
252.0	330	207.0	300
251.0	330	213.0	300
250.7	330	209.0	300
<b>- PV to N:</b>			
254.3	330	224.5	300
245.4	330	204.0	300
242.0	330	227.0	300
247.6	330	219.5	300
247.3	330	214.5	300
<b>Note:</b>			
– maximum 300mA for inverters with continuous output power rating $\leq$ 30 kVA; – maximum 10mA per kVA of rated continuous output power for inverters with continuous output power rating $>$ 30 kVA.			
This test shall be repeated 5 times, and for all 5 tests the time to disconnect shall not exceed 0,3s. The test is repeated for each PV input terminal. It is not required to test all PV input terminals if analysis of the design indicates that one or more terminals can be expected to have the same result, for example where multiple PV string inputs are in parallel.			
<b>Supplementary information:</b>			

IEC 62109-2			
Clause	Requirement + Test	Result - Remark	Verdict

<b>4.8.3.5.3</b>	<b>TABLE: Test for detection of sudden changes in residual current</b>		
------------------	--	--	--

<b>+PV to N</b>		
Limit (mA)	<b>U<sub>N</sub></b>	Limit (ms)
	<b>Disconnection time (ms)</b>	
30	199.5	300
30	200.0	300
30	198.0	300
30	216.5	300
30	219.5	300
60	121.0	150
60	123.5	150
60	118.0	150
60	127.0	150
60	107.5	150
150	25.0	40
150	35.0	40
150	22.8	40
150	31.0	40
150	24.2	40
<b>-PV to N</b>		
Limit (mA)	<b>U<sub>N</sub></b>	Limit (ms)
	<b>Disconnection time (ms)</b>	
30	193.5	300
30	218.5	300
30	217.5	300
30	222.0	300
30	218.0	300
60	109.5	150
60	111.0	150
60	123.0	150
60	119.0	150
60	121.5	150
150	16.0	40
150	33.0	40
150	28.2	40
150	19.2	40
150	20.2	40

**Note:**  
 The capacitive current is raised until disconnection.  
 Test condition:  $I_c + 30/60/150\text{mA} \leq I_{c\text{max}}$ . R<sub>1</sub> is set that 30/60/150mA Flow and switch S is closed.

**Supplementary information:**  
 100% output power and Vmppmax input voltage

**List of test equipment used:**

No.	Equipment name	Manufacture	Serial No.	Calibration Data	Usage
1	Solar IV simulator	Kewell	BZ-EP-L002	--	√
2	Solar IV simulator	Chroma	BZ-EP-L039	--	√
3	Programmable ac load	QunLing	BZ-EP-L003	--	√
4	Power analyzer	HIOKI	BZ-EP-L005	2020/02/26	√
5	Oscilloscope	Tektronix	BZ-EP-L016	2020/02/26	√
6	Heating Recoder	Agilent	BZ-EP-L021	2019/11/01	√
7	Hi-Pot & IR tester	Chroma	BZ-EP-L022	2019/10/31	√
8	Noise meter	TES	BZ-EP-L023	2020/3/10	√
9	Spring Hammer	BLS	BZ-EP-L034	2020/3/17	√
10	Digital Caliper	CHUANLIANG	BZ-SFT-L003	2019/10/31	√
11	Testing Finger B	AODESAI	BZ-SFT-L011	2019/11/1	√
12	DC Electronic Load	Itech	BZ-SFT-L028	2019/10/31	√
13	Pull and push	HANDPI	BZ-SFT-L045	2019/10/31	√
14	Electronic Scale	/	BZ-SFT-L087	2020/2/25	√
15	Thermostat	Hading	BZ-KKX-L003	2019/10/31	√
16	Sand and dust chamber	Gongwen	BZ-KKX-L010	2019/6/3	√
17	Strong flushing test device	Gongwen	BZ-KKX-L009	2019/10/31	√
18	Surge generator	/	BZ-EMC-L015	2019/6/12	√
19	Stop watch	TF	BZ-SFT-L068	2019/06/19	√
20	Ground Resistance Tester	AINUO	BZ-SFT-L033	2019.10.31	√
21	Leakage current test network	Anbiao	BZ-SFT-L111	2020/03/02	√
22	Multimeter	FULKE	BZ-EP-L033	2020/02/25	

- End of test report -

# Attachment 2 Photo documentation



Product: PV Grid inverter

Type: EVVO 1100TL-AV, EVVO 1600TL-AV, EVVO 2200TL-AV, EVVO 2700TL-AV, EVVO 3000TL-AV, EVVO 3200TL-AV



Figure 1. General view (for EVVO 1100TL-AV, EVVO 1600TL-AV, EVVO 2200TL-AV)



Figure 2. General view (for EVVO 2700TL-AV, EVVO 3200TL-AV)

## Attachment 2 Photo documentation



Product: PV Grid inverter

Type: EVVO 1100TL-AV, EVVO 1600TL-AV, EVVO 2200TL-AV, EVVO 2700TL-AV,  
EVVO 3000TL-AV, EVVO 3200TL-AV

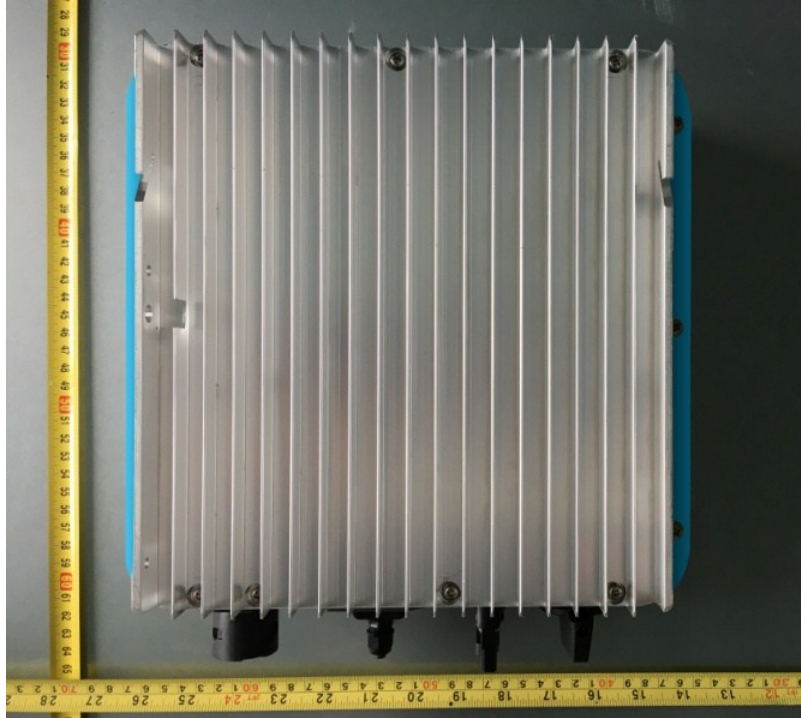

Figure 3. Back view (for EVVO 1100TL-AV, EVVO 1600TL-AV, EVVO 2200TL-AV)

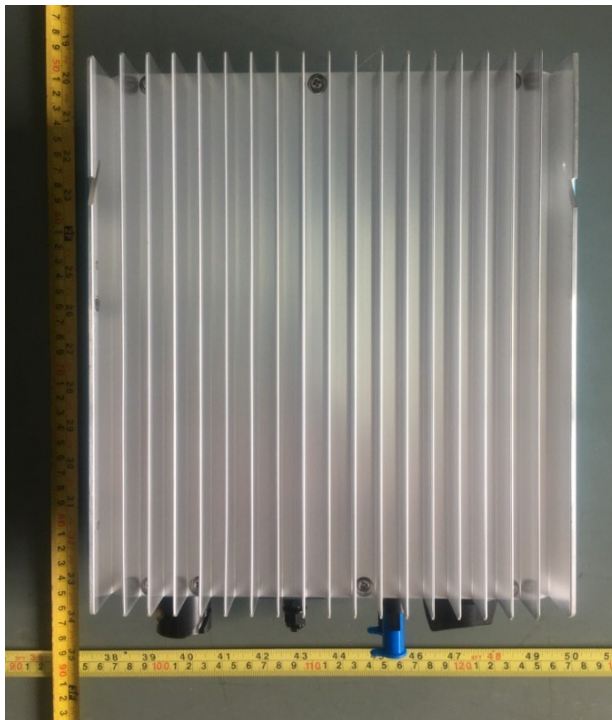

Figure 4. Back view (for EVVO 2700TL-AV, EVVO 3200TL-AV)

# Attachment 2 Photo documentation



Product: PV Grid inverter

Type: EVVO 1100TL-AV, EVVO 1600TL-AV, EVVO 2200TL-AV, EVVO 2700TL-AV, EVVO 3000TL-AV, EVVO 3200TL-AV

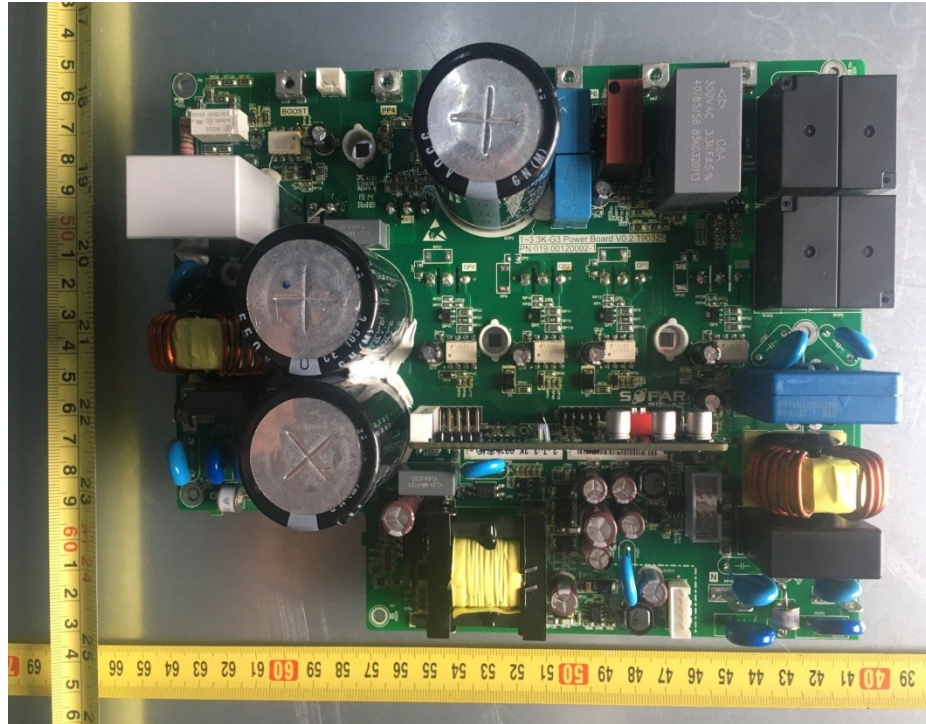

Figure 5. Front view of Main board

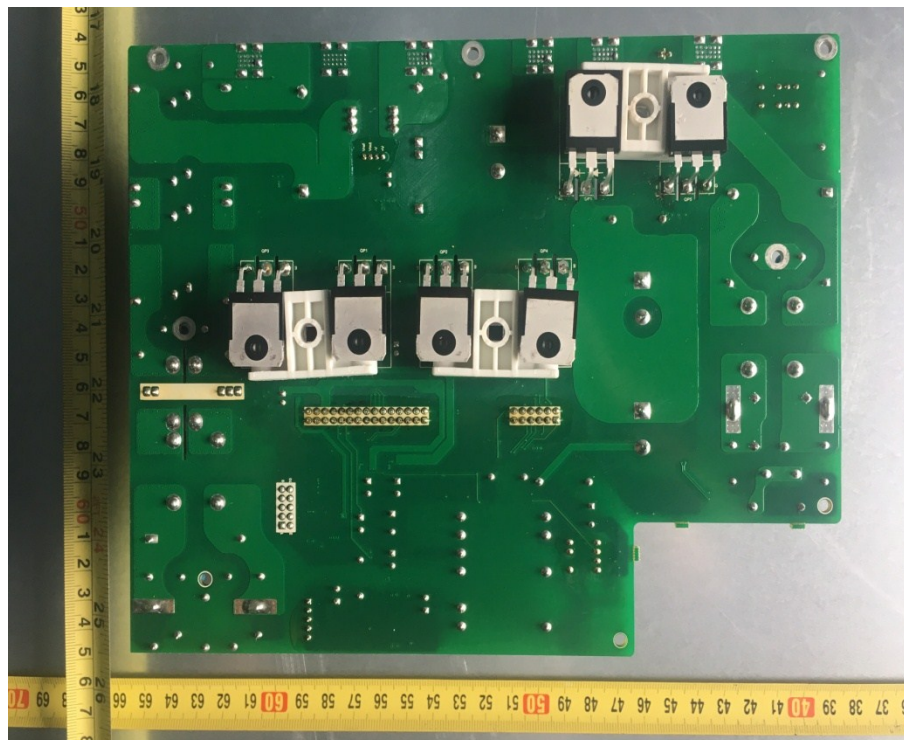

Figure 6. Back view of Main board

# Attachment 2 Photo documentation



Product: PV Grid inverter

Type: EVVO 1100TL-AV, EVVO 1600TL-AV, EVVO 2200TL-AV, EVVO 2700TL-AV, EVVO 3000TL-AV, EVVO 3200TL-AV

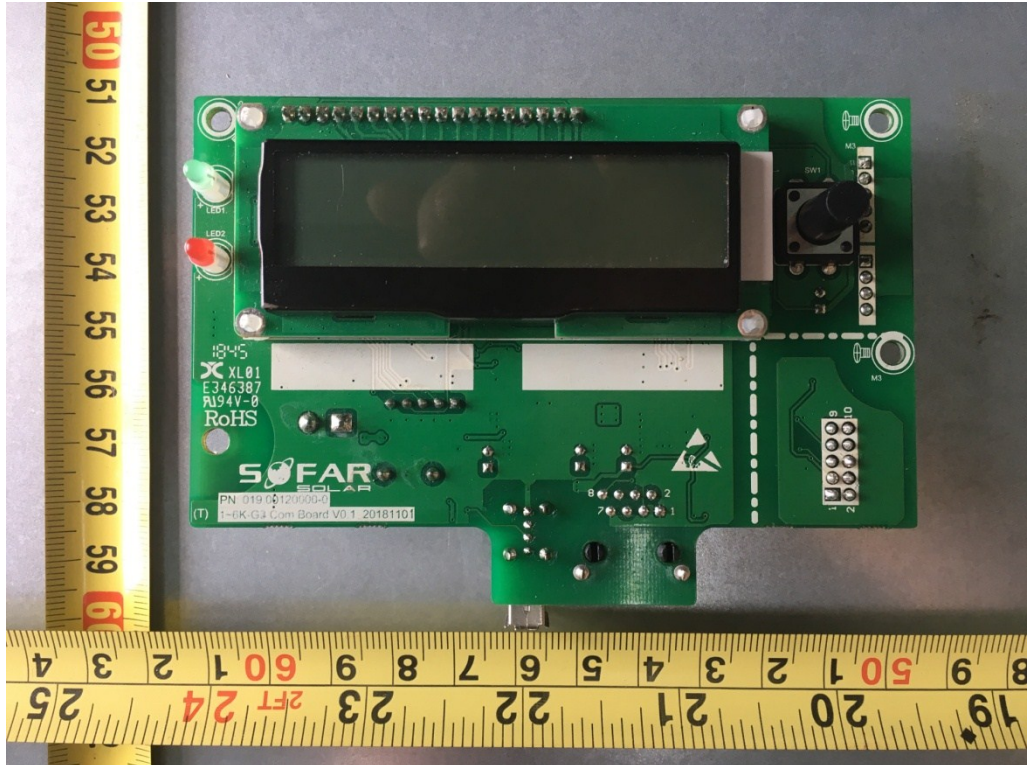

Figure 7. Front View of Display board

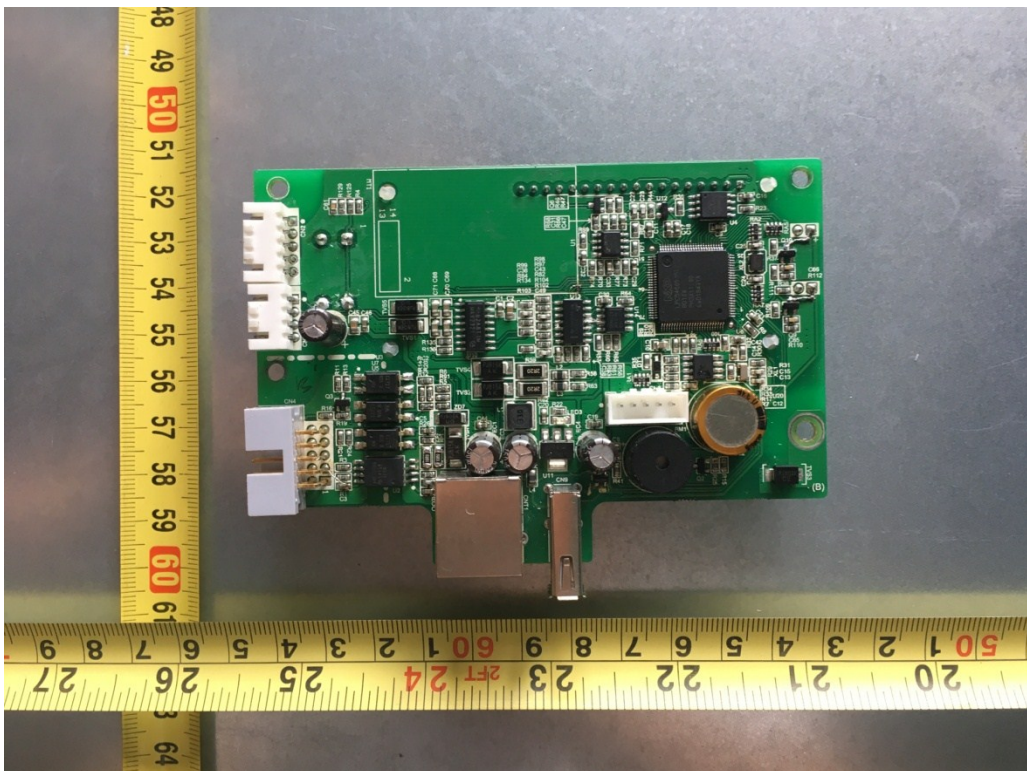

Figure 8. Back View of Display board

# Attachment 2 Photo documentation



Product: PV Grid inverter

Type: EVVO 1100TL-AV, EVVO 1600TL-AV, EVVO 2200TL-AV, EVVO 2700TL-AV, EVVO 3000TL-AV, EVVO 3200TL-AV

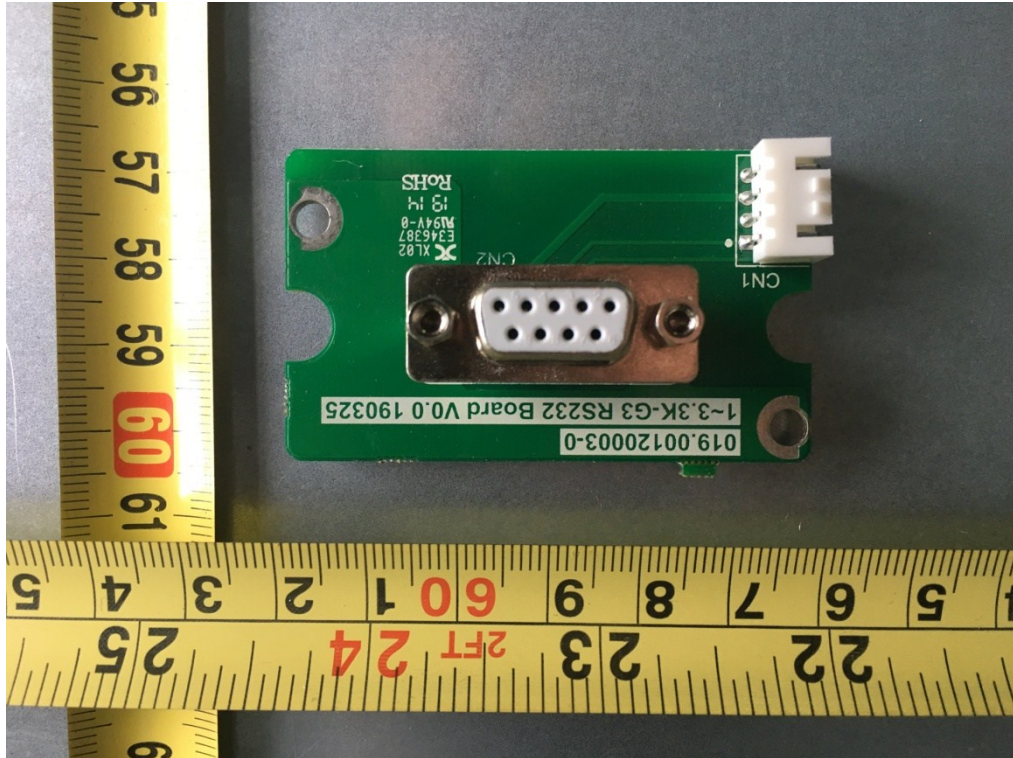

Figure 9. Front View of RS232 board

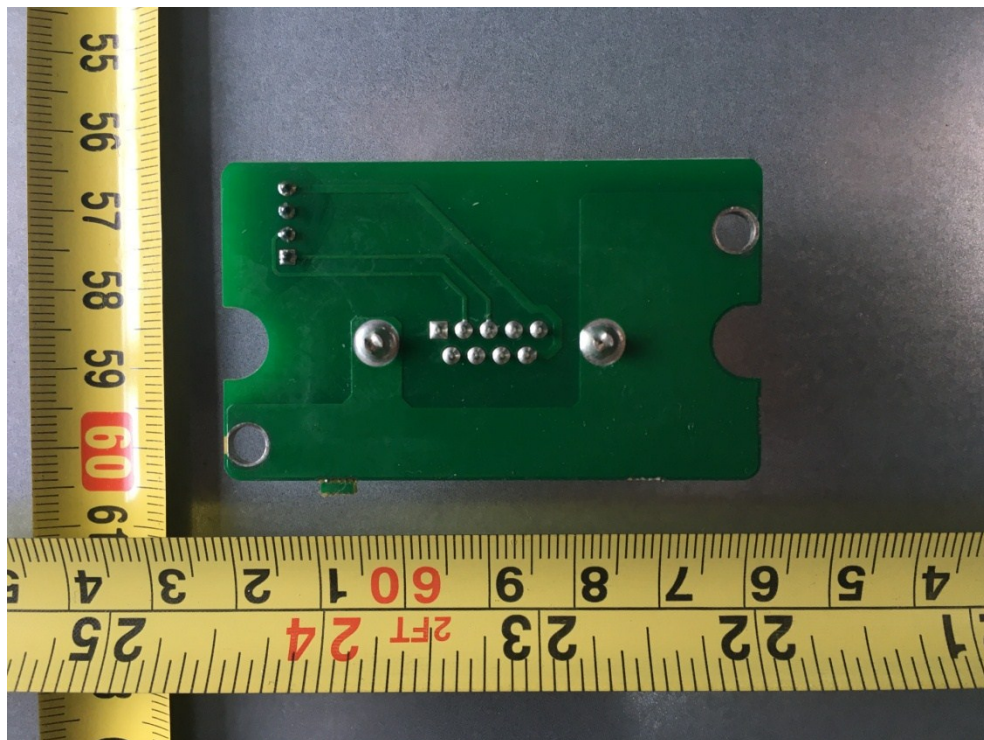

Figure 10. Back View of RS232 board



## Attachment 2 Photo documentation



Product: PV Grid inverter

Type: EVVO 1100TL-AV, EVVO 1600TL-AV, EVVO 2200TL-AV, EVVO 2700TL-AV, EVVO 3000TL-AV, EVVO 3200TL-AV

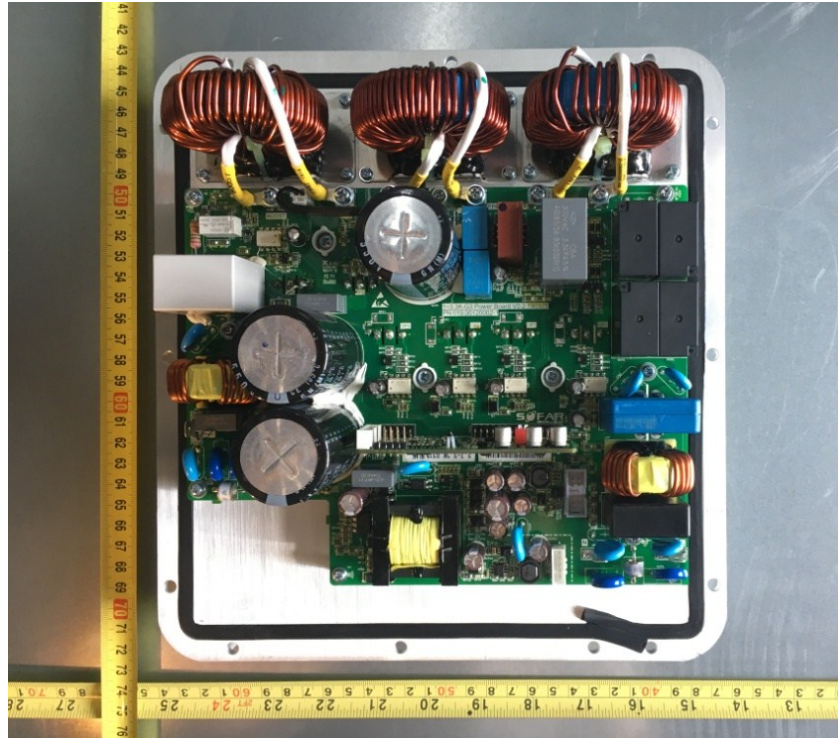

Figure 11. view of internal structure



Figure 12. Connection Interface